

EST3 System Operation Manual

P/N 270382 • REV 9.0 • ISS 13APR12

DEVELOPED BY

UTC Fire & Security
8985 Town Center Parkway
Bradenton, FL 34202
(941) 739-4300

COPYRIGHT NOTICE

© 2011 UTC Fire & Security. All rights reserved.

This manual is copyrighted by UTC Fire & Security (UTCFS). You may not reproduce, translate, transcribe, or transmit any part of this manual without express, written permission from UTCFS.

This manual contains proprietary information intended for distribution to authorized persons or companies for the sole purpose of conducting business with UTCFS. Unauthorized distribution of the information contained in this manual may violate the terms of the distribution agreement.

TRADEMARKS

Microsoft, Microsoft Mouse, and Windows are all trademarks of Microsoft Corporation.

	About this manual • iii
	The EST3 library • iv
	Important information • v
Chapter 1	Introduction • 1.1
	Introduction • 1.2
	Display operation • 1.5
	Message processing • 1.11
	Optional features • 1.13
	Entering logical addresses • 1.17
Chapter 2	3-LCD and 3-LCDXL1 operating instructions • 2.1
	Controls and indicators • 2.2
	Creating a status report • 2.9
	Disabling groups • 2.10
	Enabling groups • 2.11
	Disabling hardware components • 2.12
	Enabling hardware components • 2.13
	Arming security partitions • 2.14
	Disarming security partitions • 2.16
	Resetting security partitions • 2.17
	Bypassing security devices • 2.18
	Removing bypasses from security devices • 2.19
	Guard patrol groups • 2.20
	Changing the smoke detector sensitivity level • 2.21
	Changing event message routing • 2.22
	Changing the output state of a relay or LED • 2.23
	Creating reports • 2.24
	Setting the system time and date • 2.27
	Changing user access level passwords • 2.28
	Restarting a panel • 2.29
	Scheduling holidays • 2.30
	Clearing the panel history file • 2.31
	Testing alarm input devices • 2.32
	Testing security input devices • 2.33
	Testing Signature devices • 2.34
	Testing the panel lamps and panel sounder • 2.35
Chapter 3	3-ASU operating instructions • 3.1
	Controls and indicators • 3.2
	Operation the Audio Source Unit • 3.4
	Optional audio zone controls • 3.7
Chapter 4	3-FTCU operating instructions • 4.1
	Controls and indicators • 4.2
	Operation • 4.4
Appendix A	System addresses • A.1
	Address format • A.2

Content

LRM addresses • A.4
Control / display module addresses • A.8
Device addresses • A.10

Appendix B

Operation sequence charts • B.1

Z

Index • Z.1

About this manual

This manual provides information on how to operate an EST3 integrated system. The information presented here is of a general nature, since each site and system is unique. The EST3 system at your site has been designed by professionals to meet the specific requirements of the fire and security codes in your location. Please refer to the site-specific instructions, provided by your UTCFS representative, to determine the exact operation of your system.

Model number JB-TBZL-EST3, used to describe the EST3 life safety system in the Chinese marketplace, carries the same UL listings and approvals as EST3 when installed and configured using the subcomponents and methodologies described in this manual.

Organization

The manual contains the following chapters:

- *Chapter 1: Introduction:* gives you a general description of system functions and operations.
- *Chapter 2: 3-LCD and 3-LCDXL1 operating instructions:* provides detailed operating instructions for the primary control module, the 3-LCD(XL1) module.
- *Chapter 3: 3-ASU operating instructions:* provides detailed operating instructions for the 3-ASU audio source unit.
- *Chapter 4: 3-FTCU operating instructions:* provides detailed operating instructions for the 3-FTCU firefighter telephone control unit.
- *Appendix A: System addresses:* contains figures that show you how to determine various device addresses.
- *Appendix B: Operation sequence charts:* contains tables or charts that show the sequence of events, actions, and displays for the most common panel operations.

The EST3 library

EST3 documents

A library of documents and multi-media presentations supports the EST3 life safety system. A brief description of each is provided below.

EST3 Installation and Service Manual (P/N 270380): Gives complete information on how to install and service the EST3 hardware. The manual also includes installation information on selected Signature Series components.

SDU Online Help (P/N 180653): Provides full online support for configuring and programming a system using the EST3 System Definition Utility program.

EST3 System Operation Manual (P/N 270382): Provides detailed information on how to operate the system and system components.

EST3 Smoke Management Application Manual (P/N 270913): Provides information for designing, programming, and testing an EST3 smoke control system

EST3 Users Self-Study Course (P/N 270684): Contains a self-paced manual and accompanying video. The course is designed for building personal, security guards, firefighters, and other individuals that may be required to operate the system.

Other documents

In addition to documents in the *EST3* library, you may find the following documents useful.

Signature Series Intelligent Smoke and Heat Detectors Applications Bulletin (P/N 270145): Provides additional applications information on the Signature series smoke and heat detector applications.

Signature Series Component Installation Manual (P/N 270497): Contains detailed mounting and wiring information for all Signature series devices.

Speaker Application Guide (P/N 85000-0033): Provides information on the placement and layout of speakers for fire alarm signaling and emergency voice communications.

Strobe Applications Guide (P/N 85000-0049): Provides information on the placement and layout of strobes for fire alarm signaling.

Important information

Limitation of liability

This product has been designed to meet the requirements of NFPA Standard 72; Underwriters Laboratories, Inc., Standard 864; and Underwriters Laboratories of Canada, Inc., Standard ULC S527. Installation in accordance with this manual, applicable codes, and the instructions of the Authority Having Jurisdiction is mandatory. UTCFS shall not, under any circumstances, be liable for any incidental or consequential damages arising from loss of property or other damages or losses owing to the failure of UTCFS products beyond the cost of repair or replacement of any defective products. UTCFS reserves the right to make product improvements and change product specifications at any time.

While every precaution has been taken during the preparation of this manual to ensure the accuracy of its contents, UTCFS assumes no responsibility for errors or omissions.

FCC warning

This equipment can generate and radiate radio frequency energy. If this equipment is not installed in accordance with this manual, it may cause interference to radio communications. This equipment has been tested and found to comply within the limits for Class A computing devices pursuant to Subpart B of Part 15 of the FCC Rules. These rules are designed to provide reasonable protection against such interference when this equipment is operated in a commercial environment. Operation of this equipment is likely to cause interference, in which case the user at his own expense, will be required to take whatever measures may be required to correct the interference.

Industry Canada information

Note: The Industry Canada label identifies certified equipment. This certification means that the equipment meets certain telecommunications network protective, operational, and safety requirements. Industry Canada does not guarantee the equipment will operate to the user's satisfaction.

Before installing this equipment, users should ensure that it is permissible to be connected to the facilities of the local telecommunications company. The equipment must also be installed using an acceptable method of connection. The customer should be aware that compliance with the above conditions may not prevent degradation of service in some situations.

Repairs to certified equipment should be made by an authorized Canadian maintenance facility designated by the supplier. Any repairs or alterations made by the user to this equipment, or equipment malfunctions, may give the telecommunications company cause to request the user disconnect the equipment.

Users should ensure for their own protection that the electrical ground connections of the power utility, telephone lines, and internal metallic water pipe system, if present, are connected together. This precaution may be particularly important in rural areas.

Caution: Users should not attempt to make such connections themselves, but should contact the appropriate electric inspection authority, or electrician, as appropriate

Note: The Load Number (LN) assigned to each terminal device denotes the percentage of the total load to be connected to a telephone loop which is used by the device, to prevent overloading. The termination on a loop may consist of any combination of devices subject only to the requirements that the sum of the Load Numbers of all the devices does not exceed 100.

Summary

This chapter provides a general description of system functions and their operation.

Content

- Introduction • 1.2
 - Password protection • 1.2
 - Feature and function domains • 1.3
- Display operation • 1.5
 - Normal state • 1.5
 - Off-normal state • 1.6
 - Message details • 1.8
 - Display priorities • 1.10
- Message processing • 1.11
 - Common event LEDs and queue buttons • 1.11
- Optional features • 1.13
 - Guard patrol • 1.13
 - System timers • 1.14
 - Time controls • 1.15
 - Control/display module buttons • 1.15
- Entering logical addresses • 1.17
 - Panels • 1.17
 - Local rail modules • 1.17
 - Devices • 1.17

Introduction

System operating requirements can be configured based on geographic location and protected premises ownership.

In North America, systems can be configured as protected premises (local) systems or as proprietary systems, both in compliance with NFPA 72.

In the local mode, there is no requirement to acknowledge each individual event. Each event message can be reviewed using the Previous and Next buttons. System events that automatically restore will automatically be removed from the message queue, without requiring the operator to view a restored message.

In the proprietary mode, each event must be individually acknowledged by pressing the respective message acknowledge button. The Previous and Next button functions are not available in the proprietary mode. Operators are required to acknowledge both an event and its restoration to remove it from a message queue.

Note: Alarm and supervisory events do not automatically restore. They remain in their respective message queues until the system is manually reset.

Password protection

Certain front-panel controls and command menu functions are password-protected and have a user access level that is determined by the marketplace setting. The four user access levels are detailed in Table 1-1.

Each access level is given a default password that should be changed once the panel is put into service. See Chapter 2: *Changing user access level passwords* for more information.

Table 1-1: Password privileges

Password Level	Privileges
Default No password required	<ul style="list-style-type: none"> • Status • Revision level report • Output selection • Display/printer selection • Printer selection • Reset function • Alarm silence function • Drill function
User access level 1	All default privileges, plus: <ul style="list-style-type: none"> • Sensitivity reports • Guard patrol routes (activate/restore)

Table 1-1: Password privileges

Password Level	Privileges
User access level 2	All default and User 1 privileges, plus: <ul style="list-style-type: none"> • History reports • Devices (enable/disable) • Zone groups (enable/disable) • Alternate sensitivity (activate) • Alternate message route (activate) • Primary sensitivity (restore) • Primary message route (restore) • Change time (program) • Change date (program) • Security devices (bypass/unbypass) • Partitions (arm/disarm) • Change password for level 1
User access level 3	All default, User 1 and 2 privileges, plus: <ul style="list-style-type: none"> • AND group (enable/disable) • Matrix group (enable/disable) • Service group (enable/disable) • Guard patrol group (enable/disable) • Instruction text (enable/disable) • Time control (enable/disable) • Switch (enable/disable) • LED (enable/disable) • Relay (activate/restore) • LED (activate/restore) • Audio amp (activate/restore) • Audio message (activate/restore) • Holiday list (program) • Change password for level 2
Service access level 4	All default, User 1, 2, and 3 privileges, plus: <ul style="list-style-type: none"> • Security functions: NONE • Output: Primary printer select • Card (LRM)(enable/disable) • Restart by panel (program) • Restart all panels (program) • Clear history (program) • Test (start/cancel) • Signature Device Test • Change password for level 3

Feature and function domains

The *domain* of a feature or function is the group of cabinets on the network that are affected when the feature or function is activated. Three domains are available:

- Local: The feature/function affects only the cabinet on which the 3-LCD or 3-LCDXL1 display module is installed
- Group: The feature/function affects a pre-defined group of cabinets on the network
- Global: The feature/function affects all the cabinets on the network

A network cabinet may be a part of one or more groups. Multiple control locations are permitted for any group.

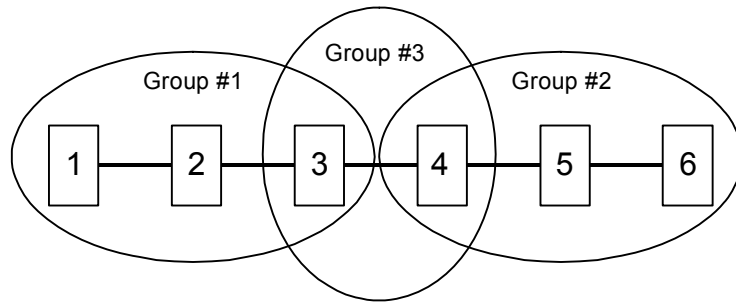

The configuration of features and functions varies with each installation. Please consult your site-specific documentation to determine if any custom features or functions have been designed into your system.

Display operation

The information presented on the main display depends on the operating condition of the panel: normal state (no events present) or off-normal state (at least one event).

Normal state

Figure 1-1 shows the information presented on the main display when the panel is in a normal operating condition.

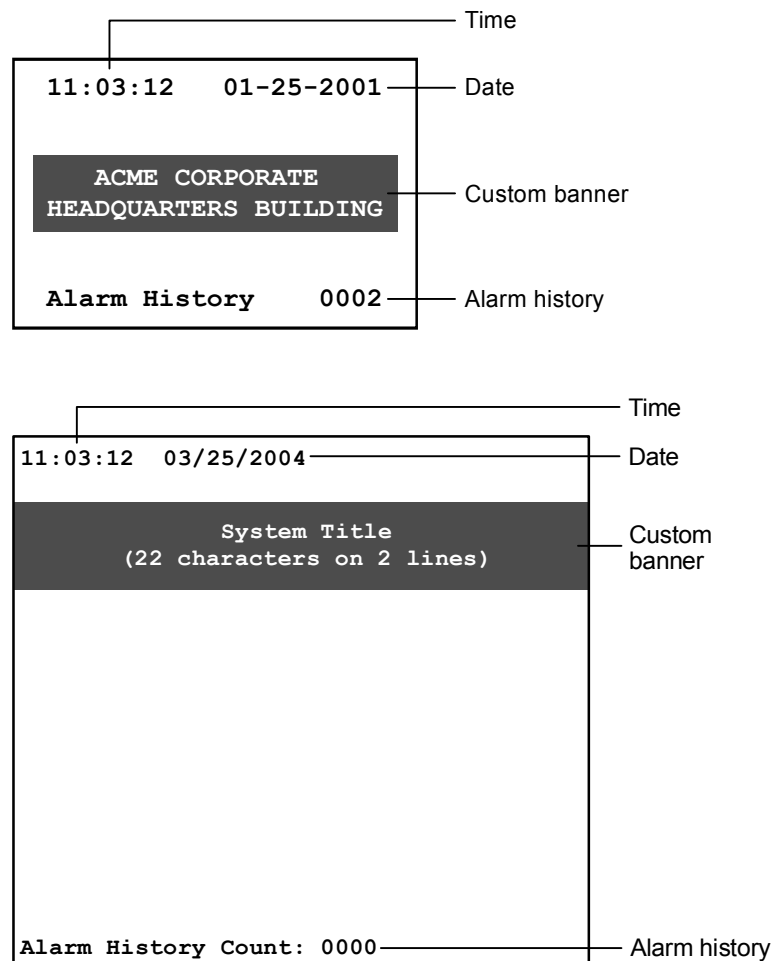

Figure 1-1: Main 3-LCD (top) and 3-LCDXL1 (bottom) display screens when the panel is in a normal state

- The top of the screen displays the system time and date. The time is in 24-hour format. The project configuration settings determine the date format.

- The middle of the screen displays an optional custom banner message, if programmed into the system. Otherwise, this area is left blank.
- The bottom of the screen displays the total number of times that the panel has gone into alarm since the last time the alarm history was cleared.

Off-normal state

Figure 1-2 and Figure 1-3 show the information presented on the main display when the panel is in an off-normal operating condition.

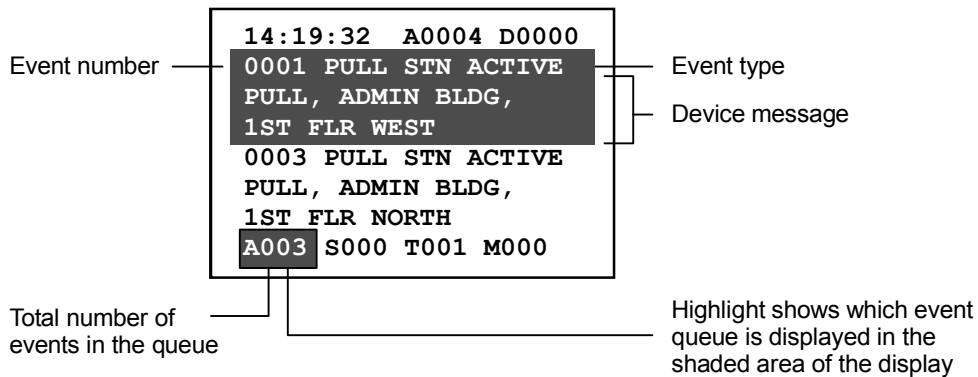
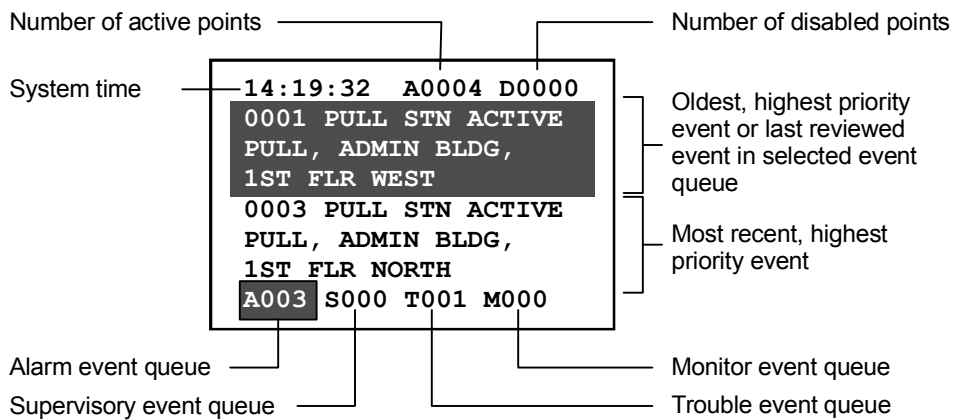

Figure 1-2: Main 3-LCD display screen when the panel is in an off-normal state

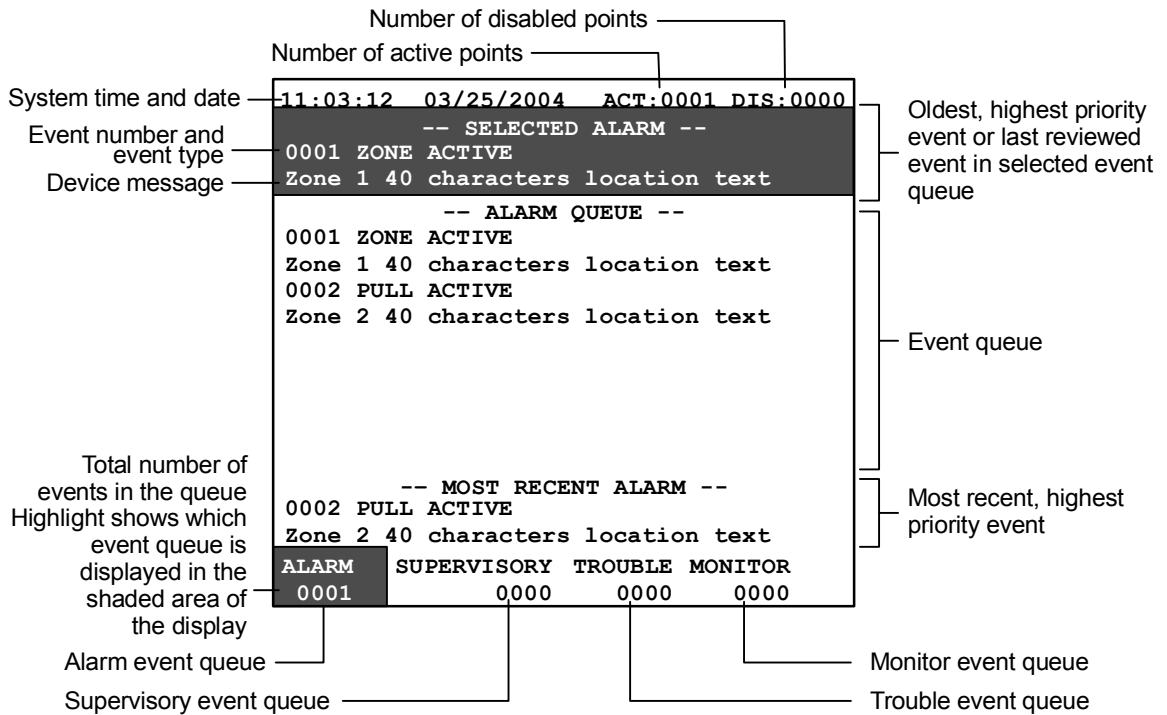

Figure 1-3: Main 3-LCDXL1 display screen when the panel is in an off-normal state

- The top line of the screen displays the system time in 24-hour format, the number of active points in the system, and the number of disabled points.
- The shaded area displays the oldest, highest priority, event received by the panel, or the last reviewed event in the selected event queue, depending on whether the display is in unattended mode (regular off-normal operation) or in attended mode. In either case, the display shows the event number, the event type, and the active device's message.

Note: Pressing any one of the queue select buttons places the display in the attended mode for reviewing or acknowledging events and prevents the shaded area from being updated by an event with a higher priority. The display automatically returns to the unattended mode after the user timeout period has expired.

- The area immediately below the shaded area on the 3-LCD always displays the most recent, highest priority event in an event queue. This area on the 3-LCDXL1 displays the event queue and the area below the event queue displays the most recent, highest priority event in an event queue.

Note: Cabinet configuration option settings determine which events are routed to the main display and placed in an event queue.

- The bottom line of the display shows the number of events in each event queue. The highlight around the event counter indicates which event queue is displayed in the shaded area.

Note: The event counter stops at 999. It is possible for an event queue to hold more than 999 events. If an event queue holds more than 999 events, “***” is displayed.

Message details

Pressing the Details button displays additional information about the event displayed on the LCD. Different detail information is displayed for each of the following:

- Device
- Group
- Guard patrol
- Instruction text

Device details

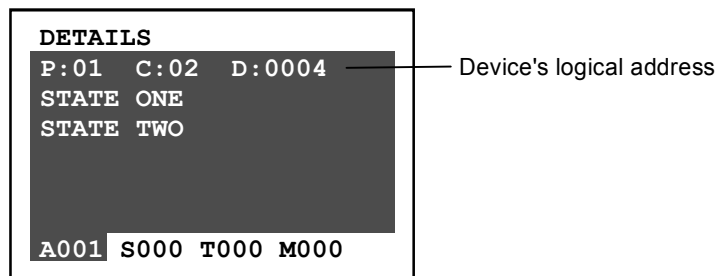

If a device activation causes the event, pressing Details displays the active device’s logical address in the following format:

P:99 C:99 D:9999

Where:

- P:99 = panel address
- C:99 = rail module address
- D:9999 = device address

Lines below the device address list the off-normal states the device is currently in.

Group details

If a group activation causes the event, pressing Details displays a series of descriptions, one for each device in the group.

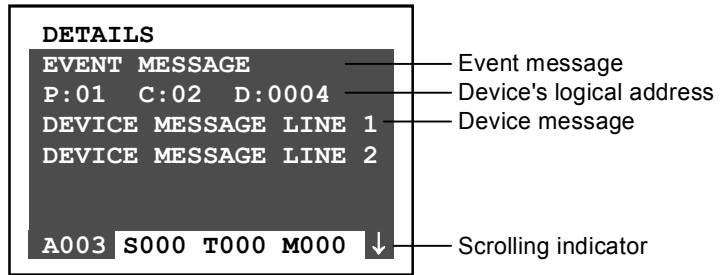

Each device panel shows the event message or state of the device, the device address, and the device message (usually the device location) which can be one or two lines long.

Guard patrol details

When a guard patrol route goes active, pressing Details displays information about the station (device) that is in alarm.

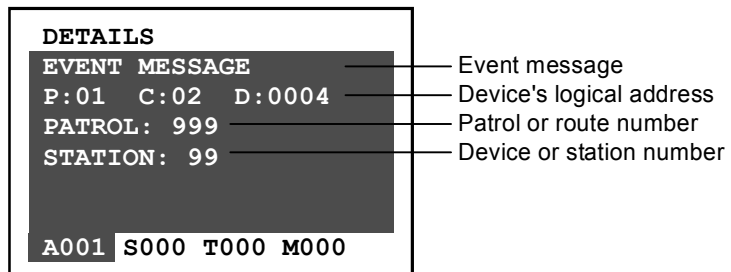

The Details panel shows the event or state of the off-normal station, as well as the logical address, patrol or route number, and station number of the device.

Instruction text details

Your system may be programmed to include detailed instructions for certain events. When specific devices go into alarm, the system generates a related monitor event. If you select the monitor event, then press Details, the instruction text is displayed.

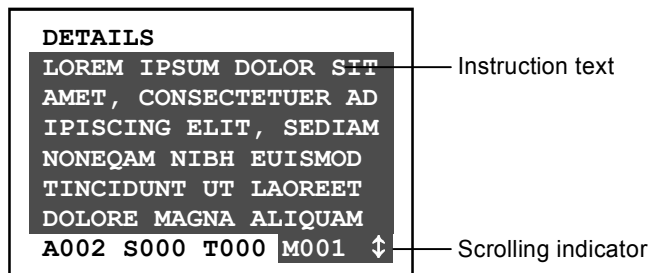

Normally, systems are designed so that instruction text is sent directly to a printer. While accessible, instruction text is not formatted for the display.

Display priorities

The panel controller places all events into one of five categories:

- Fire alarms - life safety related events, e.g. smoke detector, sprinkler system waterflow, manual pull station, etc.
- Security alarms - include burglar and holdup alarms, as generated by security devices
- Supervisory events - off normal conditions of a related fire protection system, e.g. sprinkler system valve closed.
- Trouble events - faults within the system
- Monitor events - changes in the status of an ancillary system

Because events can happen at random, the system prioritizes which event is the most critical and displays its information first. Alarm events have the highest priority and monitor events have the lowest priority.

In the U.S. Local and Proprietary market place, security events have a higher priority than monitor events and are stored in the supervisory queue. For all market place settings other than the U.S. (except the Middle East and Asia, which is the same as the U.S.) Local and Proprietary, security events, and monitor events have equal priority and are stored in the monitor queue.

Message processing

When an event occurs, the system categorizes the event as a fire alarm, security alarm, supervisory event, trouble event, or monitor event. Information about the event is added to a corresponding message queue on the 3-LCD or 3-LCDXL1 display module. The information available in each queue is displayed using the event queue buttons on the front of the LCD.

Note that for display purposes, security alarms and supervisory events are both stored in the supervisory queue.

A panel can store up to 2,000 event messages.

Common event LEDs and queue buttons

The event queue LEDs act as a common event indicator, flashing any time a new event is added to the queue.

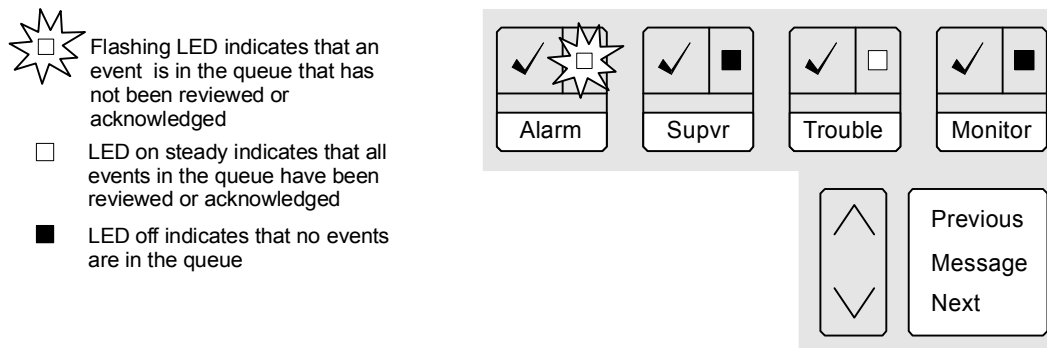

When an event is received, the respective event queue LED flashes, indicating that the event has not been reviewed or acknowledged.

1. Select the highest priority active queue by pressing the respective queue button.
2. Scroll through all available event messages using Previous/Next buttons.

You may use the Previous and Next Message or the queue buttons to scroll through the activation messages at any time after a queue is selected.

Introduction



Flashing LED indicates that an event is in the queue that has not been reviewed or acknowledged

- LED on steady indicates that all events in the queue have been reviewed or acknowledged
- LED off indicates that no events are in the queue

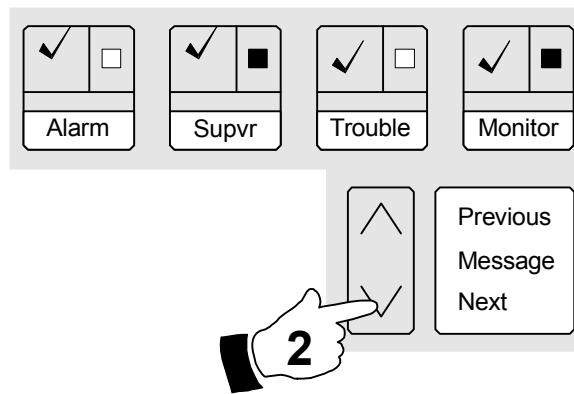
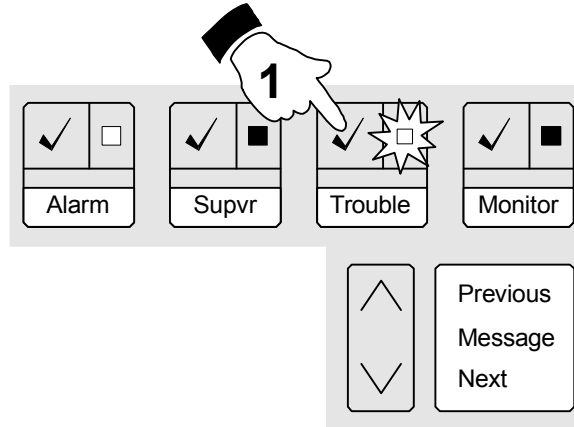

Optional features

The EST3 system can be configured with many optional features that provide additional capabilities. Your system may include some or all of these options, depending on the needs of your facility. See the site-specific information provided by your system installer to determine which options are installed.

Guard patrol

The guard patrol feature is used to monitor the activities of security guards. Guards are required to walk any one of a number of predetermined routes called tours. During each tour, the guard must activate guard patrol stations that are strategically located along the route. Should a guard activate a station too early, too late, or out of sequence, an active guard patrol message will be displayed on the panel LCD.

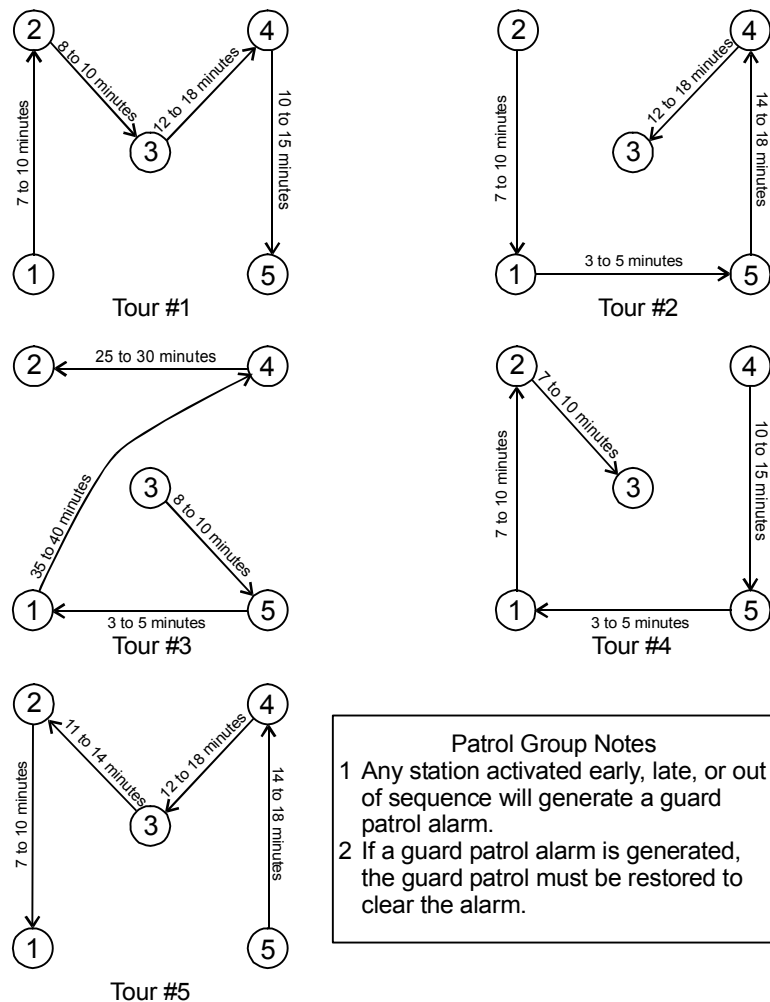

Figure 1-4: Sample guard patrol route assignments

Figure 1-4 shows five guard patrol routes consisting of five stations. The system designer has assigned a minimum and maximum time allowance for the guard to go between any two guard stations. If the guard arrives too early, too late or at the wrong station, an active guard patrol event is generated.

Starting a tour

There are three ways to start a guard patrol tour:

- Activate the first guard patrol station on the route
- Enable the Guard Patrol group from the LCD module (either 3-LCD or 3-LCDXL1)
- Press a control/display panel button programmed to turn on the Guard Patrol group

Note: A guard patrol station designated as the first station in one guard patrol route cannot be the first station in another route.

Ending a tour

A guard patrol tour is automatically ended when all stations on the route have been successfully operated within the allowable time period and in the proper sequence.

Should a tour end with an active guard patrol response, the system must be reset to clear the guard patrol response.

Press the Details button to reveal the stations reporting in.

Clearing a guard patrol alarm

When a guard patrol alarm is generated, you must restore the guard patrol route to clear the alarm. The steps are detailed later in this manual.

System timers

The system has a number of optional timers that are required by certain jurisdictions to comply with fire codes. Most of these timer functions do not require operator action, however, understanding the function of these optional timers (if enabled) will improve your understanding of why the system functions as it does.

Alarm silence/reset inhibit timer

The alarm silence/reset inhibit timer is used to guarantee that the notification appliances will sound for the minimum specified period. This timer effectively disables the alarm silence and reset buttons for a predetermined period. While the timers are active, pressing the alarm silence and reset buttons has no effect.

Notes

- Your system may be equipped with notification appliances associated with the fire sprinkler system, which cannot be silenced.
- Visual notification appliances can be configured *not* to turn off when the audible notification appliances are silenced.

Automatic alarm silence timer

The automatic alarm silence timer is used to automatically silence the notification appliances after a preset period, if they have not been silenced using the alarm silence button. Typical timer settings silence the signals from 5 to 30 minutes after operation.

Automatic general alarm (GA) timer

Some systems can be used to implement a positive alarm sequence. They are designed to permit a short investigation period between the detection of a fire and sending a general alarm to the entire facility. The automatic general alarm timer is used to initiate the general alarm after a predetermined time period, if no action has been taken by the operator to prevent the general alarm from being sent.

Time controls

Time controls provide for the automatic starting and stopping of system events based on time and date. Time controls run in the background and do not require any operator action.

Setting holidays

The system provides for special time controls, referred to as holiday time controls. Holiday time controls supersede the normal time controls on dates that are designated as holidays. The list of dates that are defined as holidays is entered into the system from the 3-LCD or 3-LCDXL1 display module.

Control/display module buttons

The buttons on a control/display module use one of three available operating modes.

- Toggle - The state of the button changes each time the button is pushed, i.e. “off” to “on” or “on” to “off.”
- Interlocked - Three adjacent toggle buttons that operate as a group. Pushing any button in the group turns the output of the other two buttons “off” and turns its own output “on.”
- Momentary - The button is “on” only while pressed by the operator.

You may find multiple button modes on a single control/display module. Consult your site-specific documentation for additional information.

Toggle buttons

Toggle buttons are commonly used to control two state operations such as on/off, open/close, speaker select, telephone select, etc. The output of an “on” button remains “on” during panel reset, and must be manually turned “off” when no longer required.

Interlocked buttons

The interlocked mode is commonly used for *hands-off auto* control of HVAC systems. An interlocked button in the “on” state can be turned “off” without activating a second button by pressing the “on” button a second time. The output of the “on” button remains on, during panel reset, and must be manually returned to “Auto” when no longer required.

Momentary buttons

Momentary buttons are typically to issue brief commands. Example uses for momentary buttons: lamp tests, function reset, and test sequences. The command is issued only while the button is pressed.

Entering logical addresses

Each addressable device or circuit in the system has a logical address. This includes panels, local rail modules, and devices. Depending on the operation you are performing, you will be prompted to enter a logical address in one of several formats.

Tip: Get an SDU Objects report for your system and keep it with this documentation. The SDU Objects report lists all of the addressable devices or circuits in the system and shows their logical addresses.

Panels

The logical address format for a panel is PP, where PP is the cabinet number (01 to 64). For example, enter 01 for the panel designated as Cabinet 1.

(System-wide events that are not related to a particular cabinet use panel number 00.)

To determine a cabinet's panel number, use the Command Menus to request a Status report. Choose any type of list. The system displays the cabinet's panel number as the default panel number. Once you've noted the panel number, press the Backspace key to exit from the function.

Local rail modules

Local rail modules include the rail modules that connect to the local rail bus and the control/display modules. The logical address format for a local rail module is PPCC, where:

- PP is the cabinet number of the panel containing the rail module
- CC is the address of the rail module
- CC+32 is the address of the control/display module connected to the rail module at slot address CC

For example, enter 0102 for the rail module installed in chassis rail 1, slot 4 of Cabinet 1. Enter 0134 for the control/display module connected to the rail module installed in chassis rail 1, slot 4 of Cabinet 1.

Note: The rail-slot number and the slot address are not the same. Slot addresses vary with the cabinet configuration. Refer to *Appendix A: System addresses*.

Devices

Devices include the circuits, buttons, or LEDs that exist on the local rail module and all addressable devices connected by the

field wiring. The address format for a device is PPCCDDDD, where:

- PP is the cabinet number of the panel containing the rail module
- CC is the address of the rail module responsible for the device
- DDDD is the address of the individual component or circuit

For example, Enter 01340129 for the first LED on the control/display module connected to the rail module installed in chassis rail 1, slot 4 of Cabinet 1.

The CRC Card Reader Controller and KPDISP Keypad Display are devices supported by a 3-SAC module. However, they also act as independent processors, and have their own points and pseudo points. For this reason, their device numbers are further subdivided.

You can think of a SAC device as having this address format: PPCCSSDD: SS is the CRC or KPDISP device number, as assigned during LRM configuration. DD is a point or pseudo point within the device.

Chapter 2

3-LCD and 3-LCDXL1 operating instructions

Summary

This chapter provides a functional description of the controls and indicators provided on the 3-LCD and 3-LCDXL1 display modules.

Content

- Controls and indicators • 2.2
- Creating a status report • 2.9
- Disabling groups • 2.10
- Enabling groups • 2.11
- Disabling hardware components • 2.12
- Enabling hardware components • 2.13
- Arming security partitions • 2.14
- Disarming security partitions • 2.16
- Resetting security partitions • 2.17
- Bypassing security devices • 2.18
- Removing bypasses from security devices • 2.19
- Guard patrol groups • 2.20
 - Starting a guard patrol • 2.20
 - Restoring a guard patrol • 2.20
- Changing the smoke detector sensitivity level • 2.21
- Changing event message routing • 2.22
 - Activating event alternate message routing • 2.22
 - Restoring event primary message routing • 2.22
- Changing the output state of a relay or LED • 2.23
- Creating reports • 2.24
- Setting the system time and date • 2.27
- Changing user access level passwords • 2.28
- Restarting a panel • 2.29
- Scheduling holidays • 2.30
- Clearing the panel history file • 2.31
- Testing alarm input devices • 2.32
- Testing security input devices • 2.33
- Testing Signature devices • 2.34
- Testing the panel lamps and panel sounder • 2.35

Controls and indicators

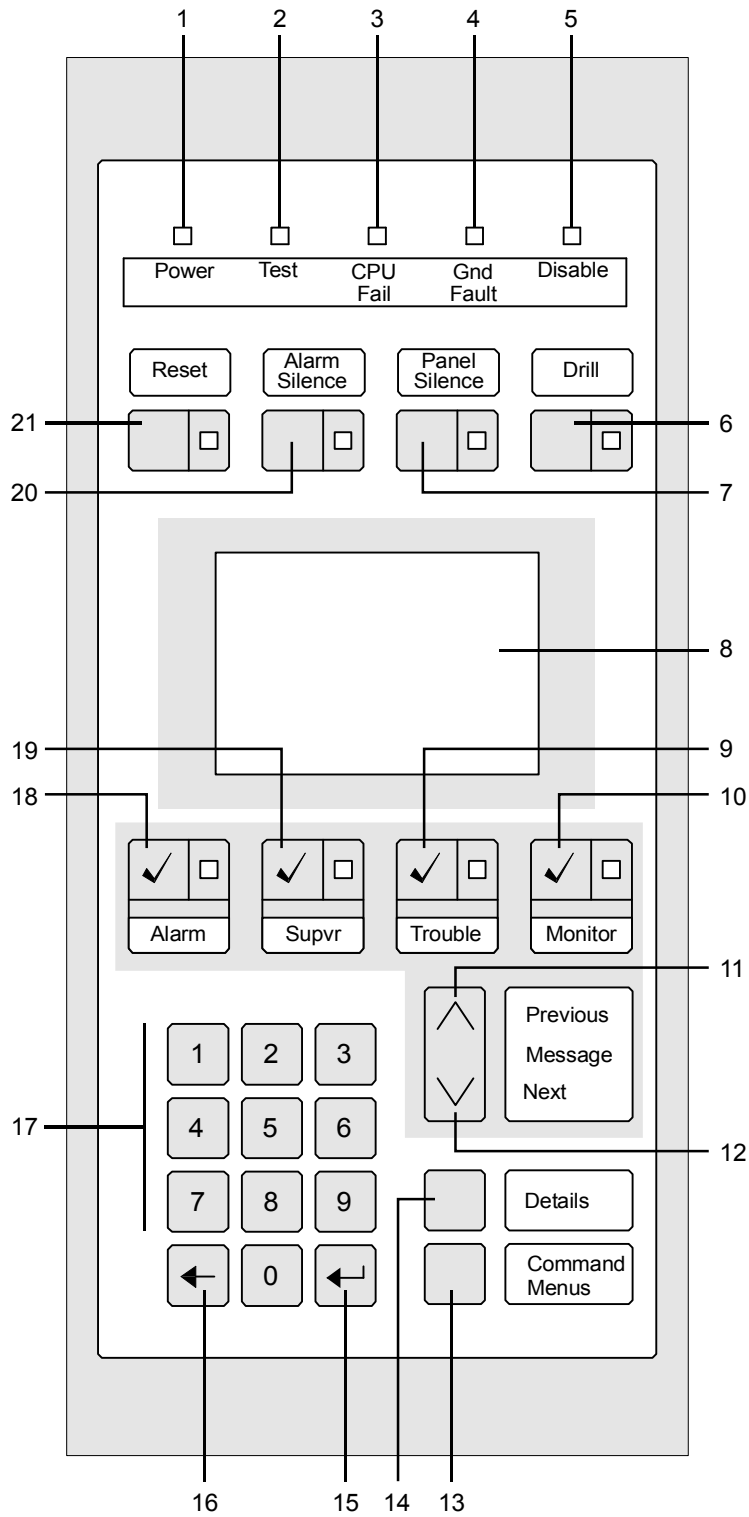

Figure 2-1: 3-LCD controls and indicators

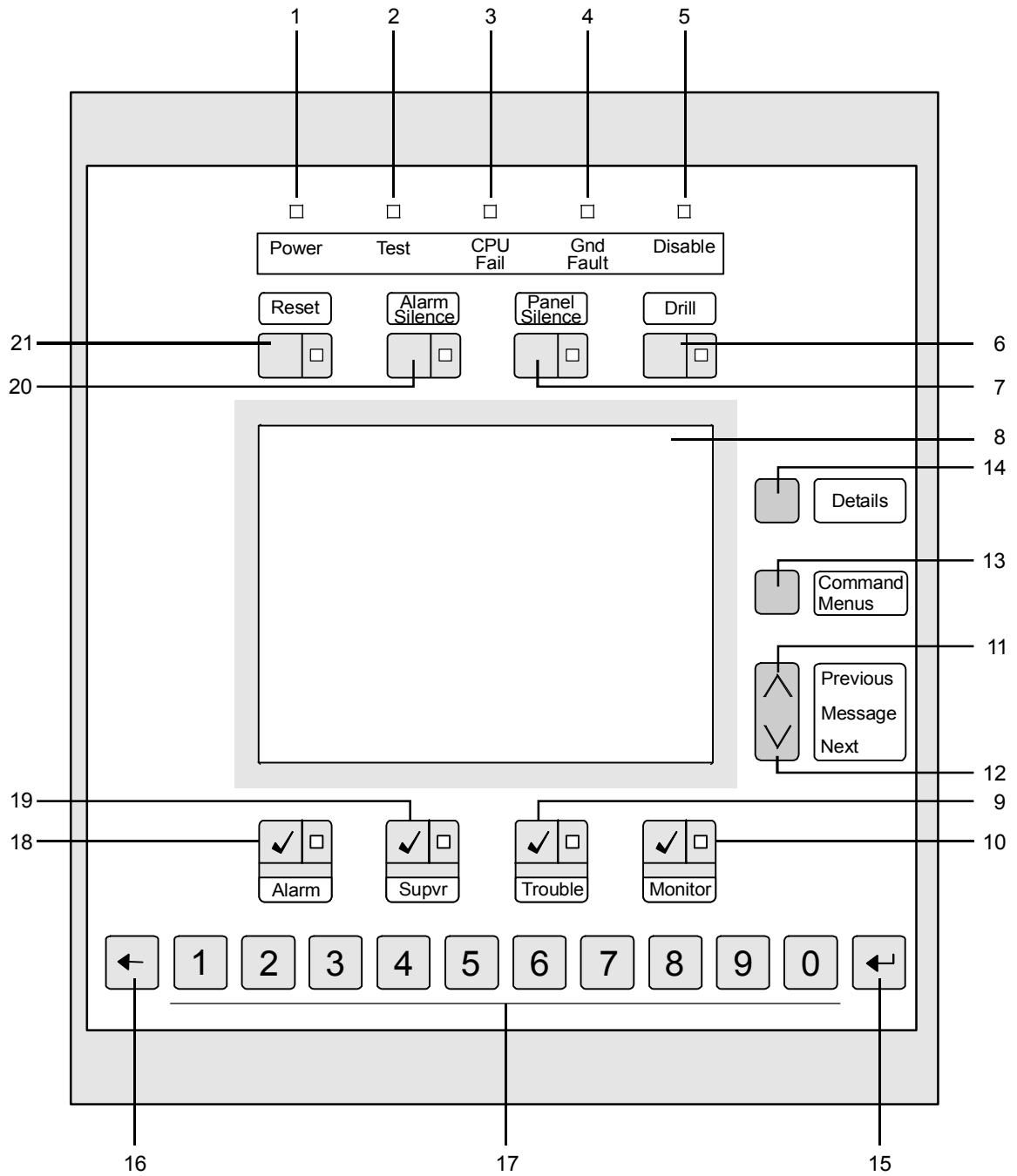

Figure 2-2: 3-LCDXL1 controls and indicators

3-LCD and 3-LCDXL1 controls and indicators (see Figure 2-1 and Figure 2-2)

Index	Control or indicator	Functional description
1	Power LED	The Power LED indicates that mains AC is applied to the panel.
2	Test LED	The Test LED indicates that a part of the system is in test mode. A programmable timer automatically exits the test mode after a period of system inactivity.
3	CPU Fail LED	The CPU Fail LED indicates the CPU module has detected a processor failure. Processor failures must be reset manually.
4	Gnd Fault LED	The Gnd Fault LED indicates that the CPU module has detected a ground fault.
5	Disable LED	The Disable LED indicates that a point or zone has been disabled using the Disable command.
6	Drill Button / LED	Pressing the Drill button activates the Drill command function. The Drill LED, when lit, indicates that the Drill command function is active.
7	Panel Silence Button / LED	<p>For U.S. Local and Canadian Local systems, pressing the Panel Silence button turns the CPU buzzer off. The Panel Silence LED, when lit, indicates the panel is in an off-normal condition and the panel has been placed in Panel Silence mode.</p> <p>For U.S. Proprietary and Canadian Proprietary systems, the Panel Silence button is not operational. The panel buzzer only silences after all events have been acknowledged.</p> <p>Note: The CPU buzzer can be configured to resound at a regular interval to remind the operator that the panel has been silenced.</p>
8	Liquid crystal display screen	168 character, backlit alphanumeric display of system status.
9	Trouble Button / LED	<p>Pressing the Trouble button places the contents of the Trouble queue onto the display screen for review. Active trouble events are displayed in the order in which they are received. When a trouble event is highlighted on the display, pressing the Trouble button acknowledges the event and advances the display to the next event.</p> <p>The Trouble LED serves as a common trouble event indicator. The LED, when flashing, indicates that there is an event in the queue that has not been reviewed (local systems) or acknowledged (proprietary systems). When on steady, the LED indicates that all events in the queue have been reviewed or acknowledged.</p>

3-LCD and 3-LCDXL1 controls and indicators (see Figure 2-1 and Figure 2-2)

Index	Control or indicator	Functional description
10	Monitor Button / LED	<p>Pressing the Monitor button places the contents of the Monitor queue onto the display screen for review. Active monitor events are displayed in the order in which they are received. When a monitor event is highlighted on the display, pressing the Monitor button acknowledges the event and advances the display to the next event.</p> <p>The Monitor LED serves as a common monitor event indicator. The LED, when flashing, indicates that there is an event in the queue that has not been reviewed (local systems) or acknowledged (proprietary systems). When on steady, the LED indicates that all events in the queue have been reviewed or acknowledged.</p>
11	Previous Message Button	<p>For U.S. Local and Canadian Local systems, pressing the Previous Message button scrolls the display to show the preceding event in the selected event queue. Reviewing events using the Previous Message button does not acknowledge the event.</p> <p>For U.S. Proprietary and Canadian Proprietary systems, the Previous event button is not operational. Events must be acknowledged in order of their occurrence.</p> <p>Note: Press and hold for auto-scroll.</p>
12	Next Message Button	<p>For U.S. Local and Canadian Local systems, pressing the Next Message button scrolls the display to show the following event in the selected event queue. Reviewing events using the Next Message button does not acknowledge the event.</p> <p>For U.S. Proprietary and Canadian Proprietary systems, the Next Message button is not operational. Events must be acknowledged in order of their occurrence.</p> <p>Note: Press and hold for auto-scroll.</p>
13	Command Menus Button	<p>Pressing the Command Menus button displays the system command menu to access the following system functions: Status, Enable, Disable, Activate, Restore, Control Output, Reports, Program, and Test</p> <p>Pressing the button a second time returns the user to the current event window.</p>

3-LCD and 3-LCDXL1 controls and indicators (see Figure 2-1 and Figure 2-2)

Index	Control or indicator	Functional description
14	Details Button	<p>Pressing the Details button displays additional information about the event highlighted on the display screen.</p> <ul style="list-style-type: none"> • For Zone Groups, pressing the Details button displays a list of the active devices in the zone group. • For Instruction Text Groups, pressing the Details button displays the entire instruction text. • For Maintenance Alerts, pressing the Details button displays a list of the dirty devices. • For Common Troubles, pressing the Details button displays a list of the specific troubles for the selected device. • For Guard Patrols, pressing the Details button displays the offending station and indicates whether the activation was caused because of an early, late, or out of sequence condition.
15	Enter key	Pressing the Enter key selects the highlighted menu option or causes the system to start processing the information shown in the display.
16	Delete / Backspace key	Pressing the Delete / Backspace key moves the cursor to the left of the current position and removes the character from the display. The Delete / Backspace key is also used to cancel functions and move the operator back through the menus.
17	Numeric Keypad	Pressing any number key selects the menu item or enters the respective number into the system for use in conjunction with other system functions.
18	Alarm Button / LED	<p>Pressing the Alarm button places the contents of the Alarm queue onto the display screen for review. Active alarm events are displayed in the order in which they are received. When an alarm event is highlighted on the display, pressing the Alarm button acknowledges the event and advances the display to the next event.</p> <p>The Alarm LED serves as a common alarm event indicator. The LED, when flashing, indicates that there is an event in the queue that has not been reviewed (local systems) or acknowledged (proprietary systems). When on steady, the LED indicates that all events in the queue have been reviewed or acknowledged.</p>

3-LCD and 3-LCDXL1 controls and indicators (see Figure 2-1 and Figure 2-2)

Index	Control or indicator	Functional description
19	Supvr Button / LED	<p>Pressing the Supervisory button places the contents of the Supervisory queue onto the display screen for review. Active supervisory events are displayed in the order in which they are received. When a supervisory event is highlighted on the display, pressing the Supervisory button acknowledges the event and advances the display to the next event.</p> <p>The Supervisory LED serves as a common supervisory event indicator. The LED, when flashing, indicates that there is an event in the queue that has not been reviewed (local systems) or acknowledged (proprietary systems). When on steady, the LED indicates that all events in the queue have been reviewed or acknowledged.</p> <p>Note: Security events allow for multiple activations from the same point. It is not uncommon for this to happen.</p>
20	Alarm Silence Button / LED	<p>Pressing the Alarm Silence button turns off the EVAC and ALERT channels, and all active audible and visible notification appliance circuits. Pushing the button a second time turns the notification appliance circuits back on. This button may be used to cancel the drill signal.</p> <p>The Alarm silence LED, when lit, indicates that the active notification appliance circuits have been silenced.</p> <p>Note: Project configuration settings affect the operation of the Alarm Silence function</p>
21	Reset Button / LED	<p>Pressing the Reset button activates the system's reset sequence to restore the system to normal.</p> <p>The Reset LED flashes quickly during the smoke power-down phase, flashes slowly during the power-up phase, is on steady during the restoral phase, and is off when the system has reset.</p> <p>Notes</p> <ul style="list-style-type: none"> • The Reset button is disabled as long as the alarm silence inhibit timer is running • The Reset button does not affect disabled points or manually overridden functions • The Reset button may not affect security or access control devices. These points may be included in the supervisory or monitor display queues.

3-LCD and 3-LCDXL1 controls and indicators (see Figure 2-1 and Figure 2-2)

Index	Control or indicator	Functional description
n/a	Buzzer	<p>The buzzer on the CPU sounds to alert the operator to off-normal system conditions, such as:</p> <ul style="list-style-type: none"> • Active alarms • Active test or disabled zones • Active fault conditions • Active monitor conditions <p>The buzzer sounds a pattern associated with each event as determined by the market place settings.</p> <p>Alarm: 3-3-3 pattern</p> <p>Supervisory: 2-2 pattern</p> <p>Trouble: 15 pulses per minute</p> <p>Monitor: 3-3-3 pattern</p>

Creating a status report

Use the Status command to create reports of off-normal points, or to determine the status of points in a security partition. The Status command generates a list that you can view on the LCD module or print on a local printer.

The Status Menu lets you choose the following reports:

- All active points
- Alarm points
- Supervisory points
- Trouble points
- Monitor points
- Test points
- Disabled points
- Output points
- Security points

On the Security Status Menu, you can choose between Partition and Holdup status reports.

To create a status report:

1. Press the Command Menus button, then choose Status.
2. Choose the type of list you want to generate.
3. Enter the target panel's 2-digit address (PP).

—or—

Choose a partition from the Partition List.

4. Do one of the following:

Choose Display if you want to view the list on the LCD module (either 3-LCD or 3-LCDXL1).

Choose Print Locally, then select a printer, if you want to send the list to a printer connected to the local panel.

Disabling groups

A *group* is an object created during system programming. Groups are required in order to execute certain system functions, but groups bear no physical relationship to the system.

For example, smoke detectors can be assigned to the same *zone group* even though they are not attached to the same wire run.

Disabling a group isolates the group from the system just as if it were a hardware component. Disabling a zone group disables each of the devices in the group individually. Disabling other groups only disables the group response.

There are several types of group:

- And group
- Matrix group
- Service group
- Guard patrol group
- Zone group
- Instruction text group

When you disable a group, the CPU lights the Disable LED on the LCD module and places a *Disabled Active* event in the trouble queue.

Note: Before disabling a group, you need to know which devices are included in the group. You should be able to get a list of logical groups and their members from the company that installed the system.

To disable a group:

1. Press the Command Menus button, then choose Disable.
2. Choose Group.
3. Choose the group type.
4. Select the group from the list.
5. If prompted, enter a valid user access level password.

Enabling groups

A *group* is an object created during system programming. Groups are required in order to execute certain system functions, but groups bear no physical relationship to the system.

For example, smoke detectors can be assigned to the same *zone group* even though they are not attached to the same wire run.

Enabling a group establishes the group as part of the system just as if it were a hardware component. When enabled, any changes in state that occurred while the group was disabled are processed. Enabling a zone group enables each of the devices in the group individually. Enabling other groups only enables their group response.

There are several types of group:

- And group
- Matrix group
- Service group
- Guard patrol group
- Zone group
- Instruction text group

To enable a group:

1. Press the Command Menus button, then choose Enable.
2. Choose Group.
3. Choose the group type.
4. Select the group from the list.
5. If prompted, enter a valid user access level password.

Disabling hardware components

Disabling a hardware component isolates the component from the system. While disabled, a component's state changes are not processed. For example, if a disabled smoke detector changes to the alarm state, the panel will not go into alarm. The panel will go into alarm if you enable the disabled smoke detector and the smoke detector is still in the alarm state.

Hardware components include:

- Devices (input and output circuits, detectors, and modules)
- Rail modules
- Buttons
- LEDs

When you disable a hardware component, the CPU lights the Disable LED on the LCD module and places a *Disabled Active* event in the trouble queue.

Note: To disable a component you need the component's logical address. You can get component's logical addresses from an SDU Objects report.

To disable a hardware component:

1. Press the Command Menus button, then choose Disable.
2. Do one of the following:
 - Choose Device to disable: input circuits, output circuits, detectors, or modules
 - Choose Card to disable: rail modules or control / display modules
 - Choose Button to disable: control / display module buttons
 - Choose LED to disable: control / display module LEDs
3. Enter the target component's logical address.
4. If prompted, enter a valid user access level password.

Enabling hardware components

Enabling a hardware component re-establishes a disabled component as part of the system. When enabled, any changes in state that occurred while the component was disabled are processed. For example, if you enable a smoke detector that changed to the alarm state while it was disabled the panel will go into alarm.

Hardware components consist of:

- Devices (input and output circuits, detectors, and modules)
- Rail modules
- Buttons
- LEDs

To enable a disabled component you need the component's logical address. You can get a disabled component's logical address from the disabled points list.

Note: All components are enabled at startup, unless programmed otherwise. The LCD module does not indicate a trouble for any points disabled at startup and points disabled at startup are not listed on the disabled points list.

To enable a hardware component:

1. Press the Command Menus button, then choose Enable.
2. Do one of the following:
 - Choose Device to enable: input circuits, output circuits, detectors, or modules
 - Choose Card to enable: rail modules or control / display modules
 - Choose Button to enable: control / display module buttons
 - Choose LED to enable: control / display module LEDs
3. Enter the component's logical address.
4. If prompted, enter a valid user access level password.

Arming security partitions

A 'Partition' can comprise any combination of security, fire, supervisory, and monitor device types as well as system pseudo points. Note that only security device types will generate security alarm events. Partition alarm events are not annunciated on the 3-LCD, they only get annunciated in FireWorks, Keypad Display units, or as activated LEDs on 3-ANNs and Envoy. Non-security device types will not trigger Partition Alarm events. There is virtually no limit on the number of 'objects' that can be assigned to a single partition.

A security partition is a group of devices intended to secure a physical area. When you arm a partition, you instruct the system to monitor those devices for armed alarm events.

Partitions can be armed for two states: *Stay* and *Away*. Arming to Stay causes the system to monitor only those devices on the perimeter of the protected area. This leaves you free to move about inside the partition. Arming to Away causes the system to monitor all devices, both perimeter and interior.

Before arming the partition, the system checks all the devices in the partition to ensure that they're in the normal state. Typically, if a device is off-normal it may prevent the partition from being armed. However, you can elect to disable the off-normal device and arm the remaining devices in the partition.

When commanded to conditionally arm, the partition may arm directly or may generate an error or warning under the following conditions:

- The Partition is configured to issue a warning (not error) for non-security objects that are "off-normal". If non-security objects are configured to issue an error on Partition arming, then the Partition will always issue an error message and will not arm conditionally when any one single error device is "off-normal". When this occurs, the Partition can only be 'forced' into an arm state.
- The total number of "off-normal" non-security devices plus the total number of bypassed or disabled regular security devices do not exceed the maximum number of bypassed/disabled devices (as set in the 3-SDU.)
- When security devices are in a "Test" condition (see Testing Security Devices), the Partition will arm with no warning even if the number of devices in "Test" exceed the 3-SDU setting for maximum number of bypassed/disabled devices.

Partitions can be commanded to arm unconditionally (i.e., forced arm) irrespective of the error or warning conditions presented, via the following methods:

- An SDU Rule activated by a switch on an EST3 panel.
- An unconditional arm command is issued via FireWorks. This also requires the proper user access level.

Note: Issuing an unconditional forced arm command to a Partition may result in undesirable false security alarm events.

After choosing to arm the partition, the system displays a list of partitions. Scroll through this list and select the partition you wish to arm.

Note: 3-LCD and 3-LCDXL1 security commands are optional. Cabinet configuration settings determine whether security commands appear on the panel menus.

To arm a security partition:

1. Press the Command Menus button, then choose Security.
2. Choose Partition.
3. Choose the type of arming you want: Partition Away or Partition Stay.
4. Scroll through the Partition List and choose the partition you want to arm.
5. If prompted, enter a valid user access level password.

Disarming security partitions

A security partition is a group of devices intended to secure a physical area. When you disarm a partition, you instruct the system to stop monitoring those devices for armed alarm events.

When a partition is disarmed the system generates disarmed alarm events, except for 24Hour security devices which always generate armed alarm events.

When you choose the disarm command, the system checks all the devices in the partition to ensure that they're in a normal state. If a device is in an off-normal condition while the partition is armed, the panel will restore the armed event and activate the disarmed event.

After you choose the disarm command, the system displays a list of partitions. You scroll through this list and select the partition you wish to disarm.

Note: Security commands are optional. Project configuration settings determine whether security commands appear on the panel menus.

To disarm a security partition:

1. Press the Command Menus button, then choose Security.
2. Choose Partition.
3. Choose Partition Disarm.
4. Scroll through the Partition List and choose the partition you want to disarm.
5. If prompted, enter a valid user access level password.

Resetting security partitions

A security partition is a group of devices intended to secure a physical area. When you reset a partition, you instruct the system to update the status of the devices, then update the event messages in all annunciator message queues.

When you choose the reset command, the system checks all the devices in the partition to determine their current state. Event messages previously stored in message queues are deleted, and new event messages are added as required by the current state of the devices.

After you choose the reset command, the system displays a list of partitions. Only disarmed partitions can be reset. You scroll through this list and select the partition you wish to reset.

Note: Security commands are optional. Cabinet configuration and card access settings determine whether security commands appear on the panel menus. The Partition Reset command has no effect on fire alarm devices.

To restore a security partition:

1. Press the Command Menus button, then choose Security.
2. Choose Partition.
3. Choose Partition Reset.
4. Scroll through the Partition List and choose the partition you want to reset.
5. If prompted, enter a valid user access level password.

Bypassing security devices

When you *bypass* a security device, the system suppresses the device's security alarm events, but continues to process all other events (e.g. Tamper, Fault, and Maintenance). For example, say a loading bay door is damaged so that the door contact cannot be closed. This prevents arming of the partition. As a temporary measure you can bypass the door contact to make it possible to arm the partition.

Devices can only be bypassed and unbypassed while the partition is disarmed. When armed, you cannot bypass or remove bypasses.

While bypassed, the device's alarm events are not processed. The panel will go into alarm if you unbypass the device while it is still in an alarm state.

Security points may be bypassed and disabled at the same time. In this state, the disable takes priority and only the disable state is annunciated. When the point becomes enabled, the bypass indication will once again be displayed.

Note: To bypass a device you need the device's logical address. You can get device's logical addresses from an SDU Objects report. In addition, the SDU includes a setting that defines how many points in a partition can be bypassed and still allow arming of that partition.

To bypass a security device:

1. Press the Command Menus button, then choose Security.
2. Choose Device.
3. Choose Bypass.
4. Enter the logical address of the device.
5. If prompted, enter a valid user access level password.

Removing bypasses from security devices

When you remove a bypass from a security device, the system resumes processing the device's alarm events. The panel will go into alarm if you remove a bypass from a device while it is in an active state (i.e., in its otherwise alarm position).

To unbypass a device, you need the device's logical address. You can get the logical address from the Disabled Points list.

To remove a bypass from a security device:

1. Press the Command Menus button, then choose Security.
2. Choose Device.
3. Choose Remove Bypass.
4. Enter the logical address of the device.
5. If prompted, enter a valid user access level password.

Guard patrol groups

Guard patrol groups are used to monitor the activities of security guards. A security guard can be required to walk any one of a number of predetermined tours. During each tour, the guard must activate guard patrol stations that are located along the tour.

When a guard activates a station too early, too late, or out of sequence, the LCD module displays a *Guard Patrol Active* message in the alarm message queue. The operator can press the Details button to determine which station reported in.

Starting a guard patrol

Activating a guard patrol group starts the system's early, late, and out of sequence sensing mechanisms. If a station reports in early, late, or out of sequence, the guard patrol sensing mechanisms stop and the tour is ended.

To activate a guard patrol:

1. Press the Command Menus button, then choose Activate.
2. Choose Guard Patrol Route.
3. Select the guard patrol route from the list.
4. If prompted, enter a valid user access level password.

Restoring a guard patrol

When a guard patrol tour ends because a guard patrol station was not activated at the proper time, you must restore the Guard Patrol group to which the station belonged.

To restore a guard patrol:

1. Press the Command Menus button then choose Restore.
2. Choose Guard Patrol Route.
3. Select the guard patrol route from the list.
4. If prompted, enter a valid user access level password.

Changing the smoke detector sensitivity level

Smoke detectors can operate using two levels of sensitivity, called *primary sensitivity* and *alternate sensitivity*. The system configures smoke detectors to use their primary sensitivity level (typically, less sensitive) during normal business hours. A time control then reconfigures the smoke detectors to use their alternate sensitivity level (typically, more sensitive) after hours when the premises are unoccupied.

You can use menu commands to manually switch between sensitivity levels as required. To change to the alternate sensitivity level, you activate alternate sensitivity. To change to primary sensitivity level, you restore primary sensitivity.

Note: You should be able to get a list of the primary and alternate sensitivity setting for each smoke detector from the company that installed the system.

To change to alternate sensitivity level:

1. Press the Command Menus button, then choose Activate.
2. Choose Alt. Sensitivity.
3. If prompted, enter a valid user access level password.

To change to primary sensitivity level:

1. Press the Command Menus button, then choose Restore.
2. Choose Primary Sensitivity.
3. If prompted, enter a valid user access level password.

Changing event message routing

Each device in the system is configured with a primary and alternate message routing. When a device in the system changes state, the panel connected to the device produces an event. The panel distributes the event according to the active message routing setting that is active at the time.

Activating event alternate message routing

Activating the alternate event message routing directs the panel to use the alternate routing destinations for any device that changes state.

To activate event alternate message routing:

1. Press the Command Menus button, then choose Activate.
2. Choose Alt Message Route
3. If prompted, enter a valid user access level password.

Restoring event primary message routing

Restoring the primary message directs the panel to use the primary routing destinations for any device that changes state.

To restore event primary message routing:

1. Press the Command Menus button, then choose Restore.
2. Choose Primary Msg Route
3. If prompted, enter a valid user access level password.

Changing the output state of a relay or LED

Use the Control Output command to change the output state of a relay or LED.

- A relay module can be On (energized) or Off (deenergized). In the energized state, the relay module's normally-open contacts are held closed and the normally-closed contacts are held open.
- An LED can be off, on, blink slow, or blink fast. The fast and slow blinking rate is determined by the marketplace.

Changing the output state of a relay or LED requires entering a command priority level.

Priority	Description
Set	This priority overrides low, medium, and high priority instructions and forces the device to the desired state. The set priority does not reset the device's priority counters.
Latch	This priority overrides low, medium, and high priority instructions and forces the device to the desired state. The latch priority does reset the device's priority counters.
Low	This priority forces the device to the desired state and adjusts the low priority counter accordingly.
Medium	This priority forces a device to the desired state and adjusts the medium priority counter accordingly.
High	This priority forces a device to the desired state and adjusts the high priority counter accordingly.

To change the output state of a relay or LED:

1. Press the Command Menus button, then choose Activate.
2. Choose the device type.
3. Select the desired output state.
4. Select the priority this command has over other commands affecting the same device.
5. Enter the target device's 8-digit logical address (PPCCDDDD).
6. If prompted, enter a valid user access level password.

Creating reports

The Reports command generates a report that you can view on the LCD module (either 3-LCD or 3-LCDXL1) or print on the local printer. Three types of report are available:

- Device Maintenance
- History
- Revisions
- Modcom Compliance

Device Maintenance: a list of detectors and the amount of environmental compensation they have used. You can choose to list devices in several ways.

History: a chronological list of events that have occurred on a panel since the panel was placed into service or since the last time the history was cleared.

Two versions of the History report are available: History With Text, and History Without Text. History With Text only includes devices for the targeted panel in the report. History Without Text includes devices for all panels in the report.

Revisions: a list of all the hardware and software components installed in a panel and their revision levels.

Modcom Compliance: lists the NFPA 72 compliance level of all 3-MODCOM modules in a given panel.

To create a Device Maintenance report:

1. Press the Command Menus button, then choose Report.
2. Choose device maintenance.
3. Do one of the following:
 - Choose Dirty Devices >80% then enter the target panel address (PP).
 - Choose Dirty Devices >20% then enter the target panel address (PP).
 - Choose Single Device then enter the target device address (PPCCDDDD).
 - Choose Devices On A Card to get the compensation level for all the detectors on a single loop then enter the target loop's logical address (PPCCL).
4. Send the list to the display or to the printer. If you choose to send the list to the printer, choose Printer 1 if the printer is connected to port 1 or Printer 2 if connected to port 2.

Note: If the device maintenance report is being run on a Addressable Analog Driver Controller, use the following table to determine sensitivity levels.

Addressable Analog Driver Controller device maintenance report sensitivity levels						
Type	Trouble	Normal	Alarm level 1	Alarm level 2	Alarm level 3	Trouble short
Photo	400	520 - 1610	1710	2050	2390	N/A
Ion	400	600 - 1710	1810	1960	2110	N/A
Thermal	400	500 - 1900	N/A	N/A	2000	N/A
Monitor	600	750 - 1300	N/A	N/A	1400	1800
Control	600	750 - 1300	N/A	N/A	N/A	1400

For additional information, refer to the device's installation sheet.

To create a History report:

1. Press the Command Menus button, then choose Report.
2. Choose History.
3. Choose History With Text or History Without Text.
4. Enter the target panel's 2-digit address (PP).
5. Send the list to the display or to the printer. If you choose to send the list to the printer, choose Printer 1 if the printer is connected to port 1 or Printer 2 if connected to port 2.

To create a Revisions report:

1. Press the Command Menus button, then choose Report.
2. Choose Revision Levels.
3. Enter the target panel's 2-digit address (PP).
4. Send the list to the display or to the printer. If you choose to send the list to the printer, choose Printer 1 if the printer is connected to port 1 or Printer 2 if connected to port 2.

To create a Modcom Compliance report:

1. Press the Command Menus button, then choose Report.
2. Choose Modcom Compliance.
3. Enter the target panel's 2-digit address (PP).
4. Send the list to the display or to the printer. If you choose to send the list to the printer, choose Printer 1 if the printer is connected to port 1 or Printer 2 if connected to port 2.

Setting the system time and date

Set the system time and date to configure the panel's time of day and date reference. Set the system time and date when the panel is first placed in service.

The system time of day is set in 24-hour format (HHMMSS), where: HH is the hour, MM is the minutes, and SS is the seconds.

For example:

Enter this value (HHMMSS)	To set this time
000000	12 midnight
010000	1 a.m.
115900	11:59 a.m.
120000	12 noon
130000	1 p.m.
235930	11:59:30 p.m.

To set the system time of day reference:

1. Press the Command Menus button, then choose Program.
2. Choose Change Time.
3. Enter the time in 24-hour format (HHMMSS)
4. If prompted, enter a valid user access level password.

The system date is set in a month/date/year format (MMDDYYYY), where: MM is the month number, DD is the date, and YYYY is the year. For example, to set the date for January 1, 1999, enter 01011999.

To change the system date reference:

1. Press the Command Menus button, then choose Program.
2. Choose Change Date.
3. Enter the date (MMDDYYYY).
4. If prompted, enter a valid user access level password.

Changing user access level passwords

You should change the access level passwords from their default values to prevent unauthorized access to system. You may not use the same password for more than one access level. The system default passwords are as follows:

Access Level	Default password	Access level required to change
Level 1	1111	Level 2
Level 2	2222	Level 3
Level 3	3333	Level 4
Level 4	4444	Level 5

Caution: Before changing a password, be sure to write it down on a sheet of paper and store it in a safe place.

To change a user access level password:

1. Press the Command Menus button, then choose Program.
2. Choose Edit Password.
3. Select the user access level password you want to change.
4. Enter the new 4-digit password.
5. If prompted, enter a valid user access level password.

Restarting a panel

Restarting a panel initiates the panel's start up processes without first turning off the operating power.

To restart a panel:

1. Press the Command Menus button, then choose Program.
2. Choose Restart.
3. Choose whether to restart a single panel or all panels on the network. If you choose to restart a single panel, then enter the target panel's 2-digit address (PP).
4. If prompted, enter a valid user access level password.

Scheduling holidays

Holidays vary from installation to installation and may change from year to year. By scheduling holidays, a panel can activate a time-controlled event based on whether the day is a scheduled holiday.

Note: Each panel can store up to 255 holidays.

To schedule a holiday:

1. Press the Command Menus button, then choose Program.
2. Choose Edit Holiday List.
3. Choose Add Holiday.
4. Enter the holiday's month and date (MMDD).
5. If prompted, enter a valid user access level password.

To delete a holiday from the list:

1. Press the Command Menus button, then choose Program.
2. Choose Edit Holiday List.
3. Select Delete Holiday.
4. Select the holiday from the list.
5. If prompted, enter a valid user access level password.

To change a holiday:

1. Press the Command Menus button, then choose Program.
2. Choose Edit Holiday List.
3. Choose Edit Holiday.
4. Select a holiday from the list.
5. Enter the new month and date (MMDD).
6. If prompted, enter a valid user access level password.

Clearing the panel history file

Clearing the panel's history file:

- Resets the alarm history counter on the LCD module
- Erases the list of events that occurred on the panel since the panel was placed into service or the last time the history file was cleared.

Caution: Clearing the panel history file means that all history data for the panel is permanently deleted. Entering panel 99 clears history on *all* panels in the network. This command requires a level 4 password, and is for use by an authorized service technician only.

To clear the alarm history:

1. Press the Command Menu button.
2. Choose Program, then choose Clear History.
3. Enter the panel number.
4. If prompted, enter a valid user access level password.

Testing alarm input devices

In order to test an alarm input device, the device must be part of a service group. Service groups allow alarm input devices to be activated without placing the system into alarm. The protected premises may be divided into more than one service group to make testing possible without leaving the entire premises unprotected.

Without any additional programming, you can test alarm input devices by:

- Putting the service group into test
- Activating each of the devices in the service group
- Verifying each of the devices show up on the active points list
- Canceling the test

Note: Putting a service group into test introduces a Service Group Active event in the trouble queue. You can press the Details button to verify which service group is in test.

To put a service group into test:

1. Press the Command Menus button, then choose Test.
2. Choose Start Test.
3. Select the service group.
4. If prompted, enter a valid user access level password.

To cancel the test:

1. Press the Command Menus button, then choose Test.
2. Choose Cancel Test.
3. Select the service group that is in test.
4. If prompted, enter a valid user access level password.

Note: A service group will automatically time-out and cancel after approximately 1 hour of inactivity.

Testing security input devices

The information provided in section “Testing alarm input devices” applies equally to all security input devices. However, there are certain nuances that apply to security devices only.

With the service group activated, security devices will generate Test Events only in accordance with their expected operation relative to their armed conditions.

The following example applies equally for all security device types:

For Security Interior devices, if the partition is disarmed or armed stay, Test Events will not be generated on the activation of the device. If the partition is armed away, Test Events will be generated on the activation of the device. However, there is a slight exception. If, after activating the Service Group, the Security Interior device is activated (and not restored) while the partition is disarmed, a Test Event will be generated immediately when the partition is armed even if the armed state is stay.

The exception in the above example happens as a result of a status update that occurs for all partition devices when partitions are armed. On evaluating the results of the status update, EST3 generates the Test Events after recognizing the active state of the security device with respect to the active state of the Service Group irrespective of the device type and armed conditions. This applies to all security device types.

Another rule that applies for security devices is that partitions must be disarmed and reset in order to clear all security Test Events from the Monitor queues in both EST3 and FireWorks. Canceling the service group test is not sufficient.

Testing Signature devices

From the LCD module you can place a Signature device into the alarm, prealarm, or trouble condition for testing. Signature devices include all sensors, modules, and security devices. To test a Signature device, the device must be connected to a 3-SSDC1 or 3-SDDC1.

For latching devices, you must reset the panel to restore the tested device to its normal state. Nonlatching devices restore automatically without resetting the panel.

WARNING: The AlarmTest command puts the device into alarm condition and activates its programmed alarm responses.

To test a Signature device:

1. Press the Command Menus button, then choose Test.
2. Choose Signature Device Test.
3. Choose Alarm, etc, Prealarm, etc, or Trouble.
4. Enter the device address and press the enter button.
5. When prompted, enter a valid user access level password.

Testing the panel lamps and panel sounder

From the LCD module you can test all the LEDs on the panel and the panel sounder. Performing a lamp test lights all LEDs on the panel and turns on the panel sounder for 10 seconds. After the test is finished, the LCD returns to its normal state display.

To perform a lamp test:

1. Press the Command Menus button, then choose Test.
2. Choose Lamp Test.

3-LCD and 3-LCDXL1 operating instructions

3-ASU operating instructions

Summary

This chapter provides a functional description of the controls and indicators provided on the 3-ASU Audio Source Unit. The 3-ASU is the control point for all the audio signals distributed by the system.

Content

- Controls and indicators • 3.2
- Operation the Audio Source Unit • 3.4
 - Event signaling • 3.4
 - Basic response tasks • 3.5
 - Paging sequence • 3.5
 - Phone page • 3.5
 - Paging with the remote microphone • 3.6
- Optional audio zone controls • 3.7

Controls and indicators

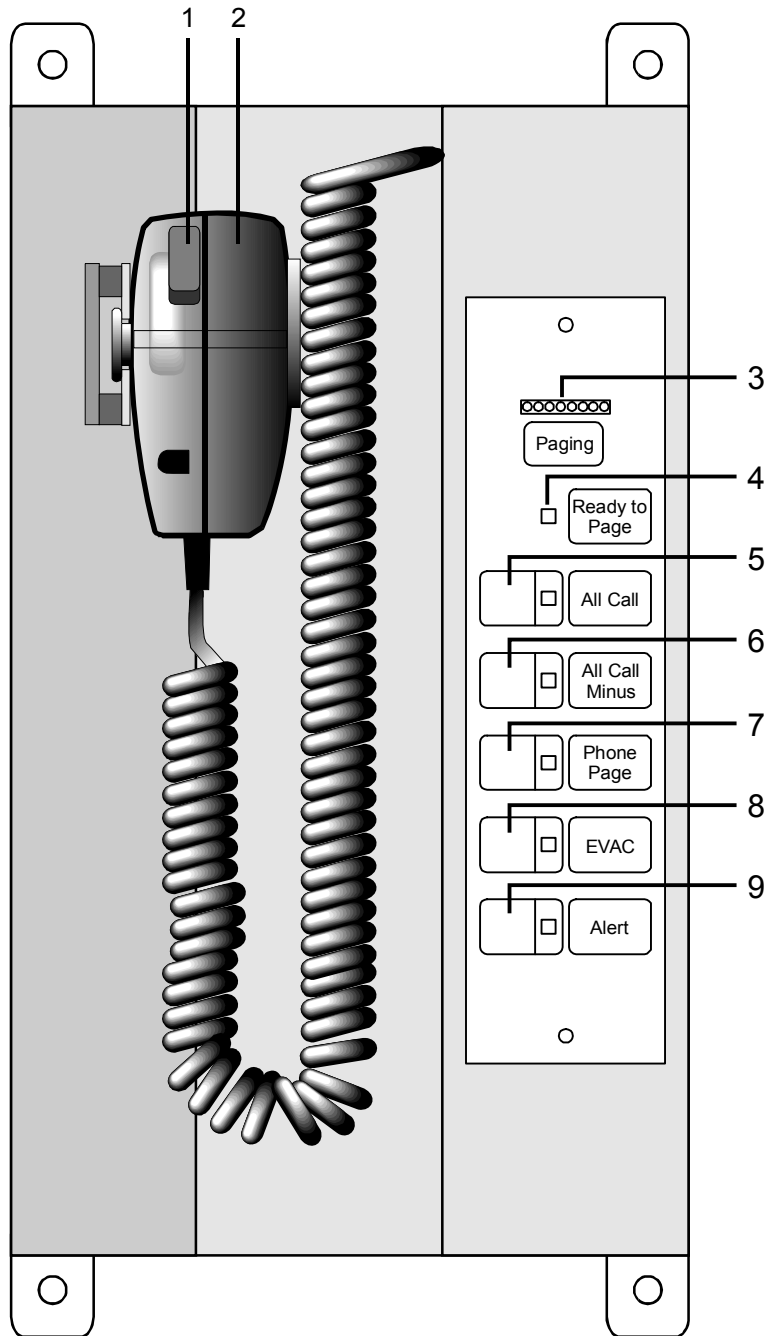

Figure 3-1: 3-ASU controls and indicators

3-ASU controls and indicators (see Figure 3-1)

Index	Control or Indicator	Functional Description
1	Push-To-Talk (PTT) Switch	Push the PTT switch and wait for the Ready to Page LED (item 4) to light steadily before making an announcement.
2	Paging Microphone	Speak into the microphone to make an announcement.
3	Page Level Meter	Indicates paging volume. When paging, speak at a level that causes the far right LED to only flicker occasionally.
4	Ready to Page LED	Green LED flashes during pre-announcement tone, then is on steady when the system is ready to page.
5	All Call Switch/LED	Green LED on indicates the 3-ASU is in the All Call mode. Pressing the All Call switch directs the page to all areas of the facility. To exit the All Call mode, press the switch a second time or press the All Call Minus, EVAC, or Alert switches.
6	All Call Minus Switch/LED	Green LED on indicates the 3-ASU is in the All Call Minus mode. Pressing the All Call Minus switch directs the page to the areas of the facility which have not been automatically selected to receive the EVAC or Alert tone/message. To exit the All Call Minus mode, press the switch a second time or press the All Call, EVAC, or Alert switches.
7	Phone Page Switch/LED	Green LED on indicates the 3-ASU is in the Phone Page mode. Pressing the Phone Page switch replaces the paging microphone (item 2) with the firefighter's telephone system. Individuals in remote areas of the facility can then issue a page via the firefighter's telephone system. All phone paging is under the direct control of the 3-ASU operator. Press the switch a second time to disconnect the Phone Page mode.
8	EVAC Switch/LED	Green LED on indicates the 3-ASU is in the EVAC mode. Pressing the EVAC switch directs the page to areas of the facility which are automatically receiving the evacuation tone/message. To exit the EVAC mode, press the switch a second time or press the All Call, All Call Minus, or Alert switches.
9	Alert Switch/LED	Green LED on indicates the 3-ASU is in the Alert mode. Pressing the Alert switch directs the page to areas of the facility which are automatically receiving the Alert tone/message. To exit the Alert mode, press the switch a second time or press the All Call, All Call Minus, or EVAC switches.

Operation the Audio Source Unit

The function of a life safety system is to alert people occupying a facility of an emergency. The Audio Source Unit is designed to permit rapid selection and paging to the affected areas of the facility. For example, the page signal automatically overrides any other signals.

Event signaling

In large facilities, the people most effected by an emergency should be instructed to evacuate the area immediately, and people not in immediate danger should receive an alert signal. Since most large facilities have a significant number of transient occupants, the most effective signaling is a combination of attention getting tones, followed by instructional messages.

The information provided here is general in nature. Each facility is unique. The life safety system in your facility has been designed by fire safety professionals to meet the specific requirements of the fire codes in your location. Please refer to the site-specific instructions provided by the installer to determine the exact operation of your system.

Evacuation (EVAC) Signaling

The evacuation signal notifies facility occupants that they are in immediate danger, and must evacuate the area. Evacuation signals can take the form of bells, horns, tones, and audio messages. Accompanying the audio message is a visual notification appliance, typically a flashing strobe light.

The system automatically activates all the evacuation signals in the affected areas of the facility.

Alert Signaling (optional)

The alert signal notifies the occupants of a facility that: an emergency event is in progress; they are not in immediate danger; and they should prepare to evacuate, but not to evacuate at this time. Alert signals are typically tones or audio messages.

The system automatically activates the alert signals (if programmed in your system) in the affected areas of the facility.

Page Messages

The most reliable source of information about an emergency event comes from the individual who is in charge of the facility during the emergency. This individual is typically the fire chief or facility manager. The page function permits the individual in charge to make announcements to selected portions of the

building, advising occupants of what actions to take for safe egress, etc.

Basic response tasks

The basic tasks in responding to an emergency event are:

1. Use the All Call function to announce the arrival of the fire department, making any necessary announcements.
2. Use the Page to Evac function to reinforce the evacuation of the occupants in areas receiving the evacuation signal. As an example, occupants may be directed to follow the evacuation plan, not to use the elevators, etc.
3. Use the Page to Alert function to notify the areas not in immediate danger to prepare to evacuate, or that people in the evacuation area may be entering their area as an area of refuge.
4. Use the All Call Minus switch to make announcements to areas of the facility not receiving the Evac or Alert signals, as required. Stairwells are typical areas accessed using the All Call Minus page function.
5. The zone page controls may be used to manually select paging areas.

Paging sequence

Select the areas to receive the page by pressing the appropriate page function switch(s). The switch's integral LED will be on steady when the system is ready to receive the page.

Press the PTT switch on the microphone. The Ready to Page LED will flash while the pre-announcement tone is sounding. Begin the announcement once the Ready to Page LED is on steady. Adjust your voice level so that the far right LED on the volume meter only flickers occasionally. Release the PTT switch when the announcement is finished. The system will turn off the page, and return to its pre-page condition after a short delay.

Note: The local microphone has priority over a telephone page, which has priority over a remote microphone page.

Each installation is customized. Please refer to your site-specific documentation to determine which areas of your facility automatically receives the page, or how to select the areas to receive the page.

Phone page

If your system is equipped with a firefighter's telephone circuit, you can connect the telephone circuit to the page function by

pressing the Phone Page switch. This permits an individual talking on the firefighter's telephone system to make announcements over the paging system.

Establish the phone connection over the Firefighter's Telephone Control Unit. Select the areas to receive the page the same way as if it were to be originated using the microphone. Instruct the individual who is remote paging to begin speaking after the pre-announcement tone has finished. Press the Phone Page Switch and begin the phone page. The phone page is under complete control of the 3-ASU/FT, and may be interrupted at any time by pressing the Phone Page switch a second time.

Paging with the remote microphone

If your system is equipped with the remote paging microphone, it may be used to issue pages throughout the facility. The remote microphone page is automatically overridden by any pages issued by the local microphone in the Audio Source Unit or a phone page.

Each remote microphone installation is customized. Please refer to your site-specific documentation to determine which areas of your facility automatically receives the page, or how to select the areas to receive the page.

Optional audio zone controls

The system can provide total manual control of the paging signals. This permits the individual in charge to extend the coverage area of the page beyond the pre-programmed areas. Your system may have the option of manually directing the page message using one of the types of control/display modules shown in Figure 3-2. The specific type and location of these displays will vary, however the basic functions are similar.

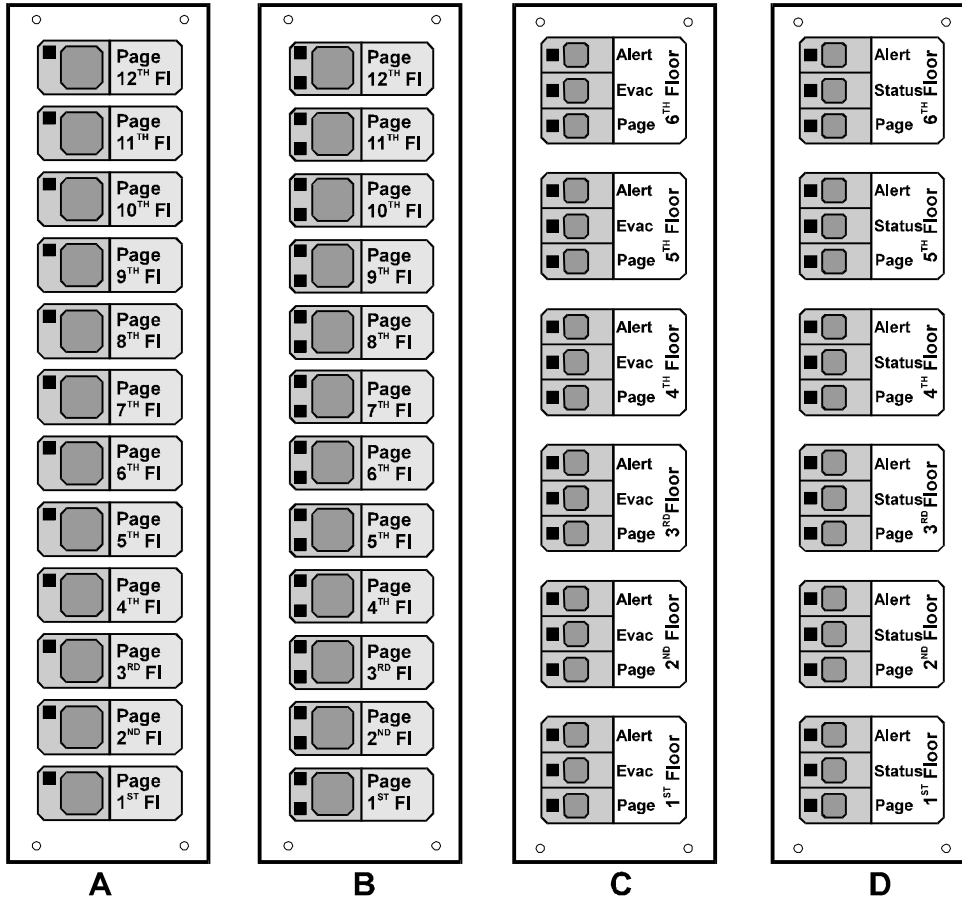

Figure 3-2: Control/display module options

Pressing a zone select switch on the displays shown in Figure 3-2A and Figure 3-2B adds that zone to any zones selected by the page function switches on the Audio Source Unit. The LED in the upper left corner of each floor's control/display module is on when the floor is selected. The LED in the lower left corner on display B is used to annunciate trouble on an amplifier or notification appliance circuit associated with the zone.

The control/display module shown in Figure 3-2C is used to manually direct the Evac and Alert signals as well as the page

message to individual areas of the facility. The LEDs can be programmed to follow any automatic system responses as well as manual audio zone selections.

The control/display module shown in Figure 3-2D is used to manually direct the Evac signal and pages to individual areas of the facility. The center switch is inoperative. This configuration is typically used in facilities where the alert signal is automatically sent to all areas not receiving the evacuation signal. The LEDs follow any automatic system responses as well as manual audio zone selections. The Status LED can be programmed to indicate the trouble state of the zone amplifier.

3-FTCU operating instructions

Summary

This chapter provides a functional description of the controls and indicators provided on the 3-FTCU Firefighter Telephone Control Unit.

Content

- Controls and indicators • 4.2
- Operation • 4.4
 - Normal condition • 4.4
 - Trouble condition • 4.4
- Answering incoming calls • 4.5
- Disconnecting calls • 4.7
- Paging by phone • 4.7

Controls and indicators

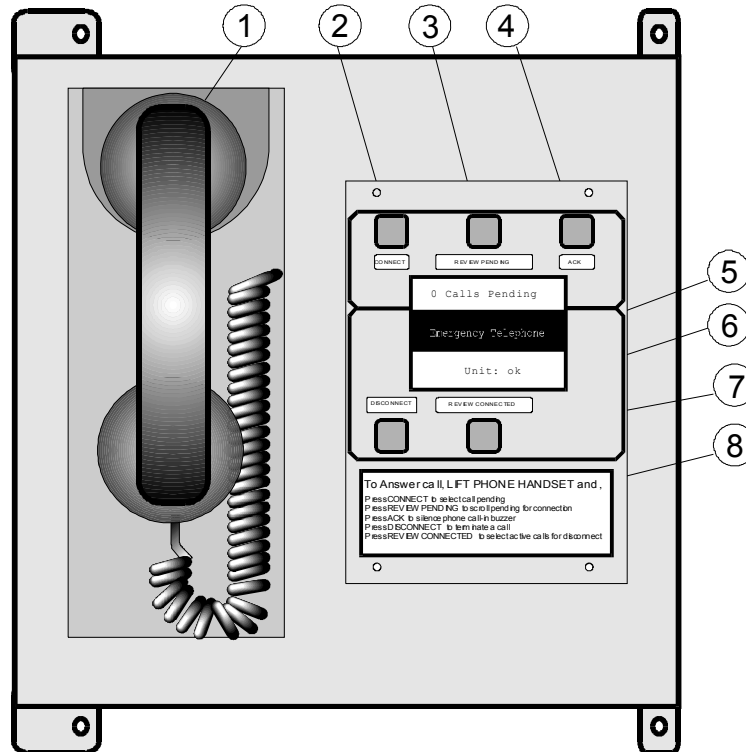

Figure 4-1: 3-FTCU controls and indicators

3-FTCU controls and indicators (see Figure 4-1)

Index	Control or indicator	Functional description
1	Master telephone handset	The master telephone handset permits the operators to communicate with dedicated firefighter telephone stations which are strategically located throughout the facility.
2	Connect switch	The connect switch connects the incoming calls to the master telephone handset.
3	Review pending switch	The review pending switch scrolls the list of pending incoming calls.
4	ACKnowledge switch	The acknowledge switch silences the call-in buzzer.
5	LCD display	The LCD display shows the status of the firefighter telephone system. The display is backlit in the alarm mode and when an incoming call is received.
6	Disconnect switch	The disconnect switch is used to remove the connected phone which is shown in reversed text on the bottom of the display.
7	Review connected switch	The review connected switch scrolls the list of connected calls on the bottom of the display.
8	Instruction placard	This card is a set of phone operating instructions.

Operation

The operational status of the phone system can be determined by using the 3-FTCU LCD display.

Normal condition

When there is no activity on the system the screen appears as shown in Figure 4-2. The top line indicates that there are no incoming calls pending.

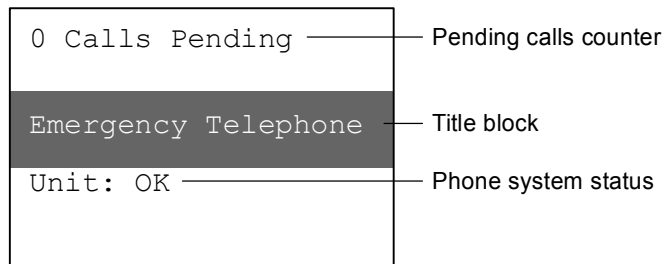

Figure 4-2: Normal display

The bottom line indicates the 3-FTCU unit status. “OK” means that there are no troubles with the phone system.

Trouble condition

When there is a fault on the firefighter telephone system, a fault indication will appear on the bottom of the display, as shown in Figure 4-3. Local faults may appear on the second line of the display. Circuit faults require the use of a 3-LCD or 3-LCDXL1 module to find the specific cause of the problem.

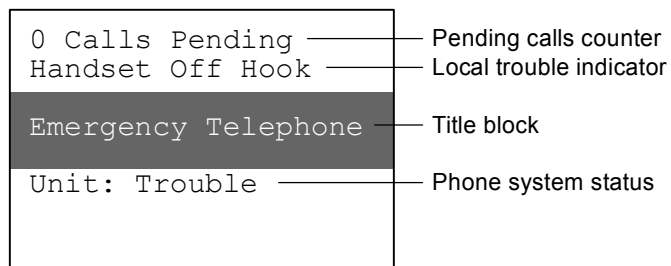

Figure 4-3: Trouble display

Answering incoming calls

An incoming call is initiated when a firefighter telephone is taken off-hook or plugged into a remote telephone jack. The caller hears a tone, indicating the connection is good, and the call-in buzzer is activated at the 3-FTCU.

Display

The number of incoming calls is always listed on the top line of the display. The identification of the incoming call appears in reversed text on the second line of the display, as shown in Figure 4-4. Should multiple calls be pending, the reversed text display will slowly sequence through the incoming calls.

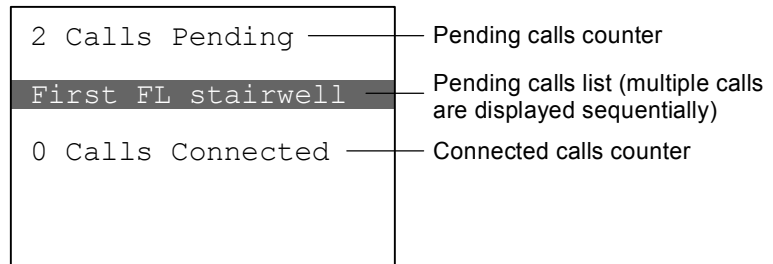

Figure 4-4: Incoming call display

To answer an incoming call

1. Silence the call-in buzzer by pressing the ACK (acknowledge) switch. The buzzer will re-sound each time a new incoming call is received.
2. If multiple calls are shown in the display, stop the call identifier sequencing by pressing the Review Pending switch once. Each additional activation of the Review Pending switch manually steps the display through the list of incoming calls. When the desired call appears on the pending calls identification line, stop stepping through the calls.
3. To answer the selected call, press the Connect switch. The call identifier will move from the pending calls identification line of the display to the connected call list at the bottom of the display, as shown in Figure 4-5. Once connected, you may begin your conversation.

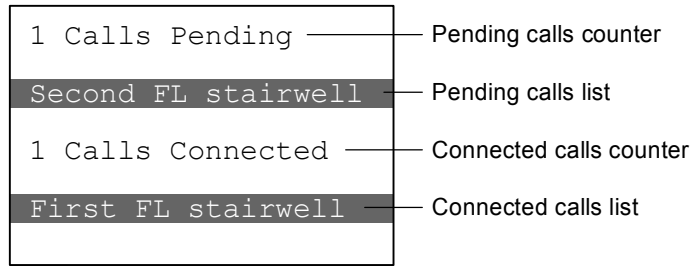

Figure 4-5: One connected call and one pending call

Notice in Figure 4-5 that the calls connected counter indicates one call connected, the first floor stairwell phone, and the pending call counter decremented to show the one remaining incoming call from the second floor stairwell phone.

4. To add the second floor stairwell phone to the conversation, press the Connect switch again. Because there is only one call pending, there is no need to scroll through incoming calls.

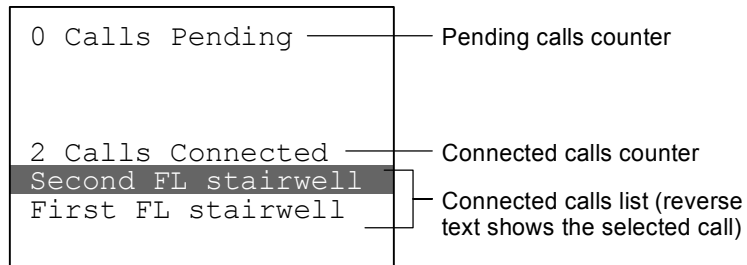

Figure 4-6: Two connected calls

The connected calls counter indicates that two phone circuits are connected, and both calls now appear in the connected calls identification list. The two stairwell phones and the 3-FTCU master handset are connected together in a party line connection, and may communicate with each other.

Up to five phone circuits can be connected in a party line connection. A full complement of connected circuits is shown in Figure 4-7.

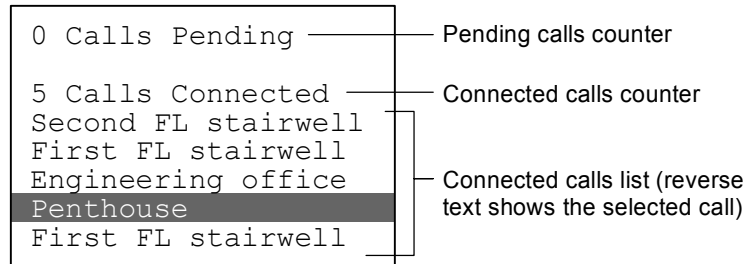

Figure 4-7: Five connected calls

Disconnecting calls

When a calling party is ready to hang up or remove a phone from its jack, the operator should disconnect the call as described below.

To disconnect a call

1. Press the Review Connected switch until the call to be disconnected is displayed in reversed text. In Figure 4-7, the Penthouse phone is selected.
2. Press the Disconnect switch. The call will be removed from the connected calls list and added to the pending calls list as shown in Figure 4-8 below. When the remote phone is hung up or removed from the phone jack, it will be removed from the calls pending list.

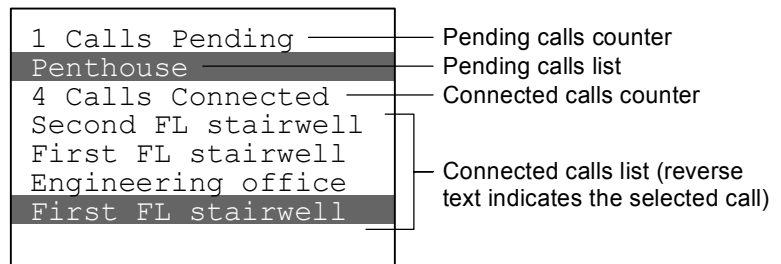

Figure 4-8: One pending call and four connected calls

3. Hanging up the master handset in the 3-FTCU transfers all connected calls to the calls pending list. If the remote phones have not been hung-up within 20 seconds, the call in buzzer will resound.

Paging by phone

The phone page feature of the 3-ASU audio source unit permits individuals with access to a remote firefighter telephone to make announcements over the emergency voice/alarm

communications system, under the supervision of the Audio Source Unit operator.

1. Establish a phone connection with the remote phone which is to issue the page.
2. Set up the areas to receive the page using one of the ASU page area functions and/or manual switch selection of additional audio zones.
3. When ready to begin the paging sequence, the ASU operator should press the Phone Page switch.
4. Begin the announcement. The 3-ASU operator can monitor the page using the master handset.

Summary

This appendix provides a quick reference for interpreting the mapping of system addresses.

Content

- Address format • A.2
- LRM addresses • A.4
- Control / display module addresses • A.8
- Device addresses • A.10

Address format

Tip: To determine a local panel's cabinet number, use the 3-LCD command menu to get the status on all the active points on the panel. When prompted for a panel number, enter 00. The panel returns the startup response point's logical address. The first two numbers of the logical address is the cabinet number.

The system derives the addresses it assigns from the panel's cabinet number and the LRM's location within the panel (see Figure A-1). The basic address format is PPCCDDDD, where:

PP is the panel's cabinet number. The cabinet number is assigned when the installer downloads the CPU database into the panel.

CC is the LRM's slot address. The cabinet number and the slot address make up the LRM's logical address.

DDDD is the device's point address. The LRM's logical address and device's point address make up the device or circuit's logical address.

The CRC Card Reader Controller and KPDISP Keypad Display are devices supported by a 3-SAC module. However, they also act as independent processors, and have their own points and pseudo points. For this reason, their device numbers are further subdivided.

You can think of a SAC device as having this address format: PPCCSSDD: SS is the CRC or KPDISP device number, as assigned during LRM configuration. DD is a point or pseudo point within the device.

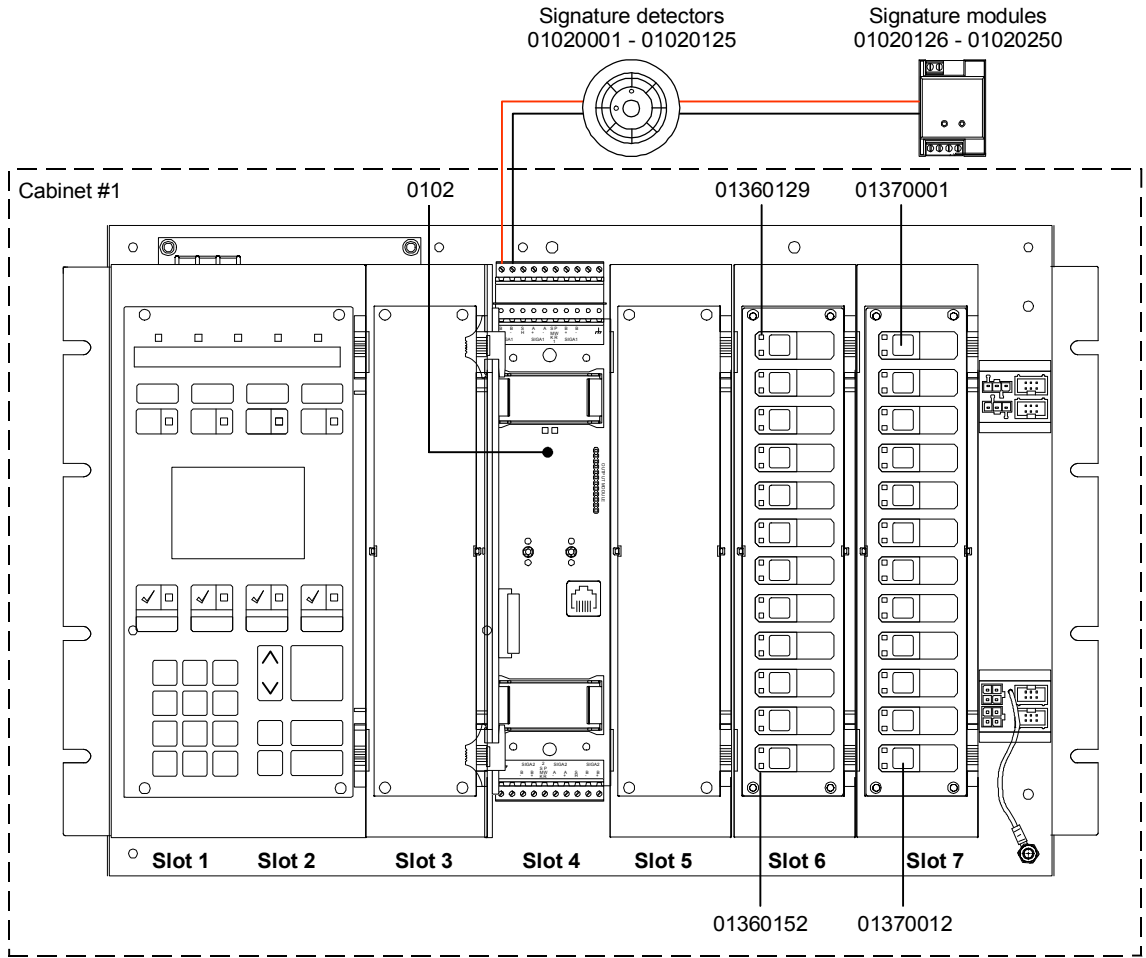

Figure A-1: Addressing example

LRM addresses

Figure A-2, Figure A-3, and Figure A-4 show the logical addresses that the system assigns to LRMs based on the panel configurations.

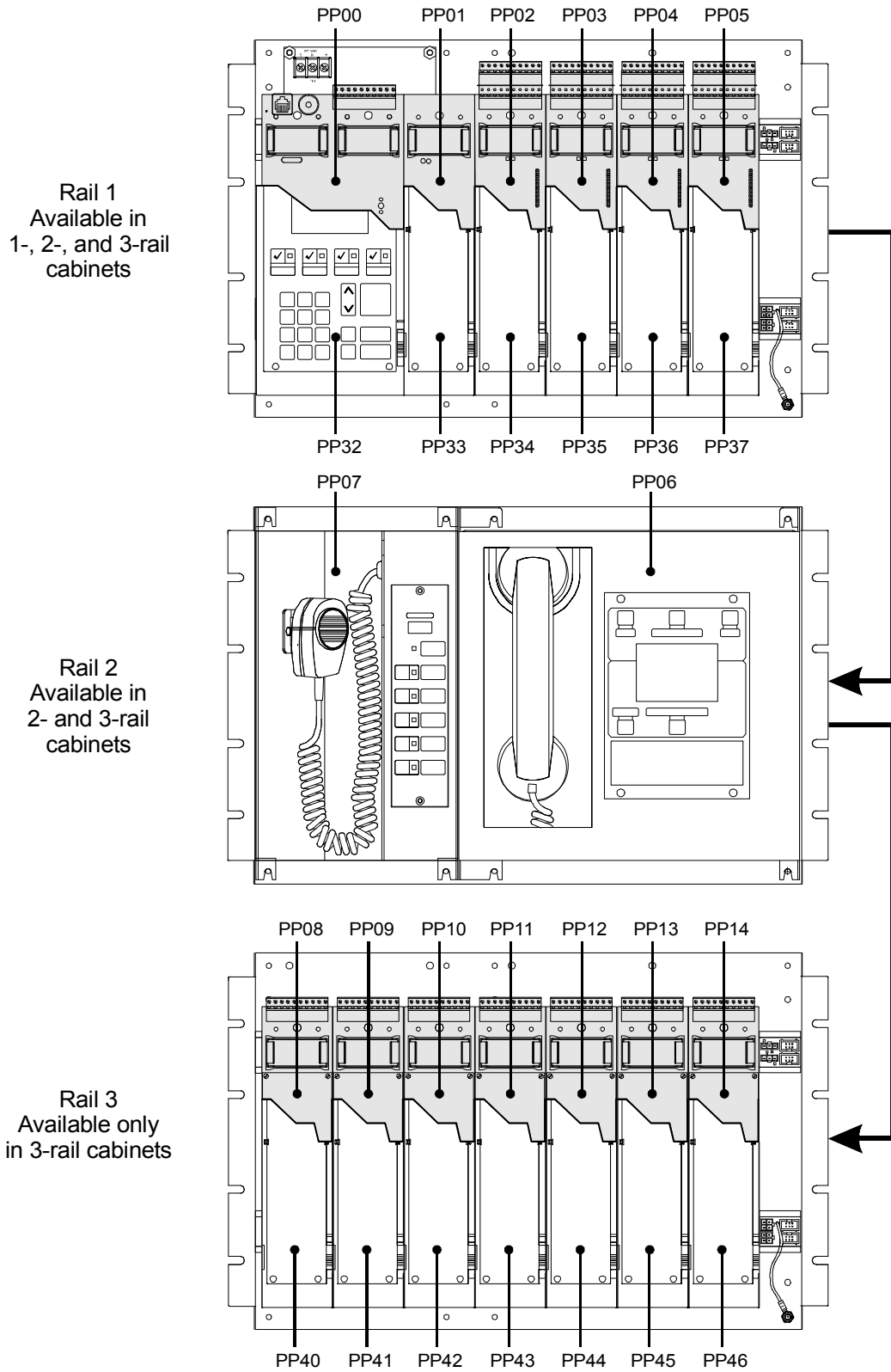

Figure A-2: LRM addresses for 3-CHAS7, 3-ASU/FT, 3-CHAS7 configuration

System addresses

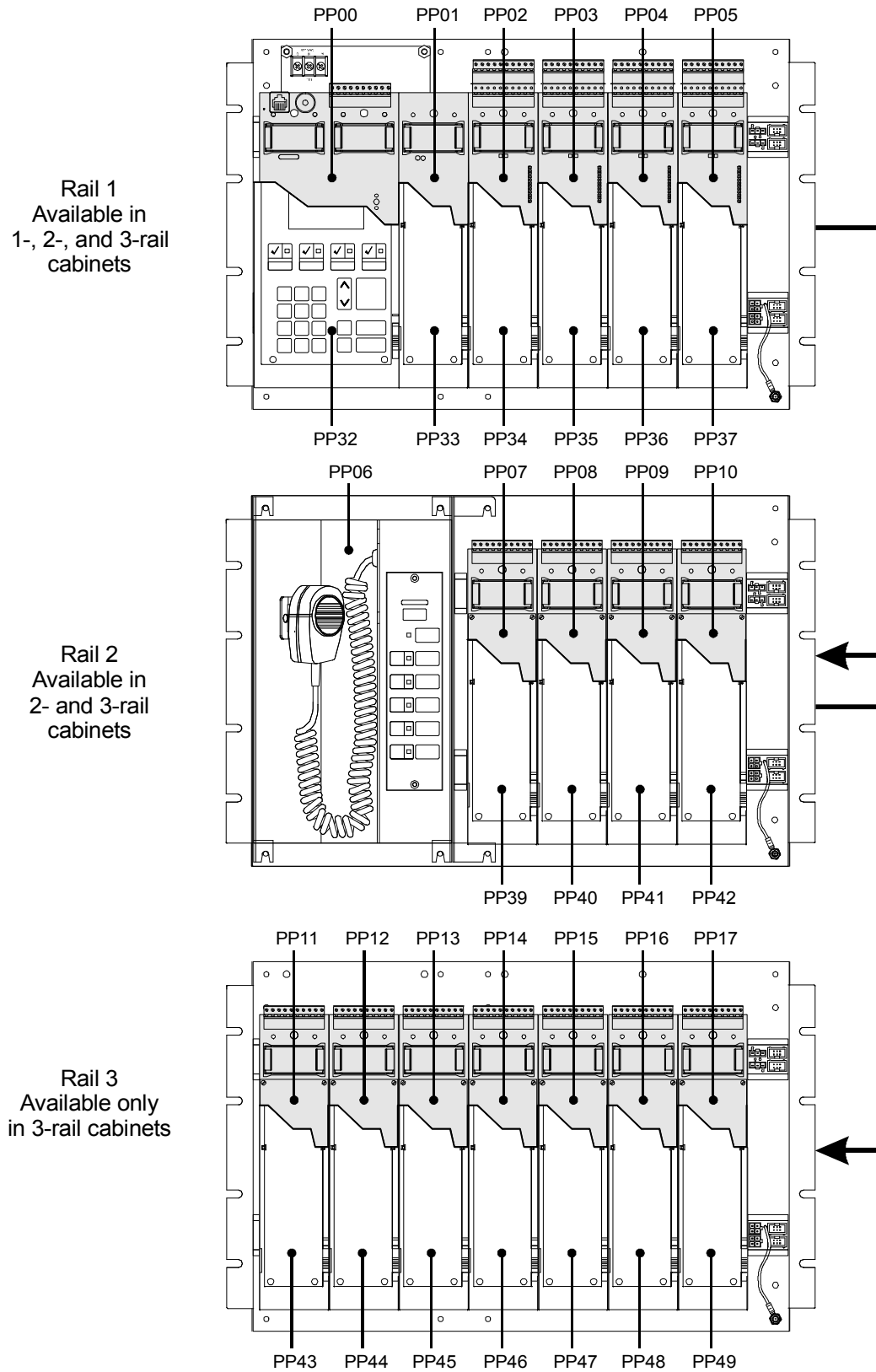

Figure A-3: LRM addresses for 3-CHAS7, 3-ASU/CHAS4, 3-CHAS7 configuration

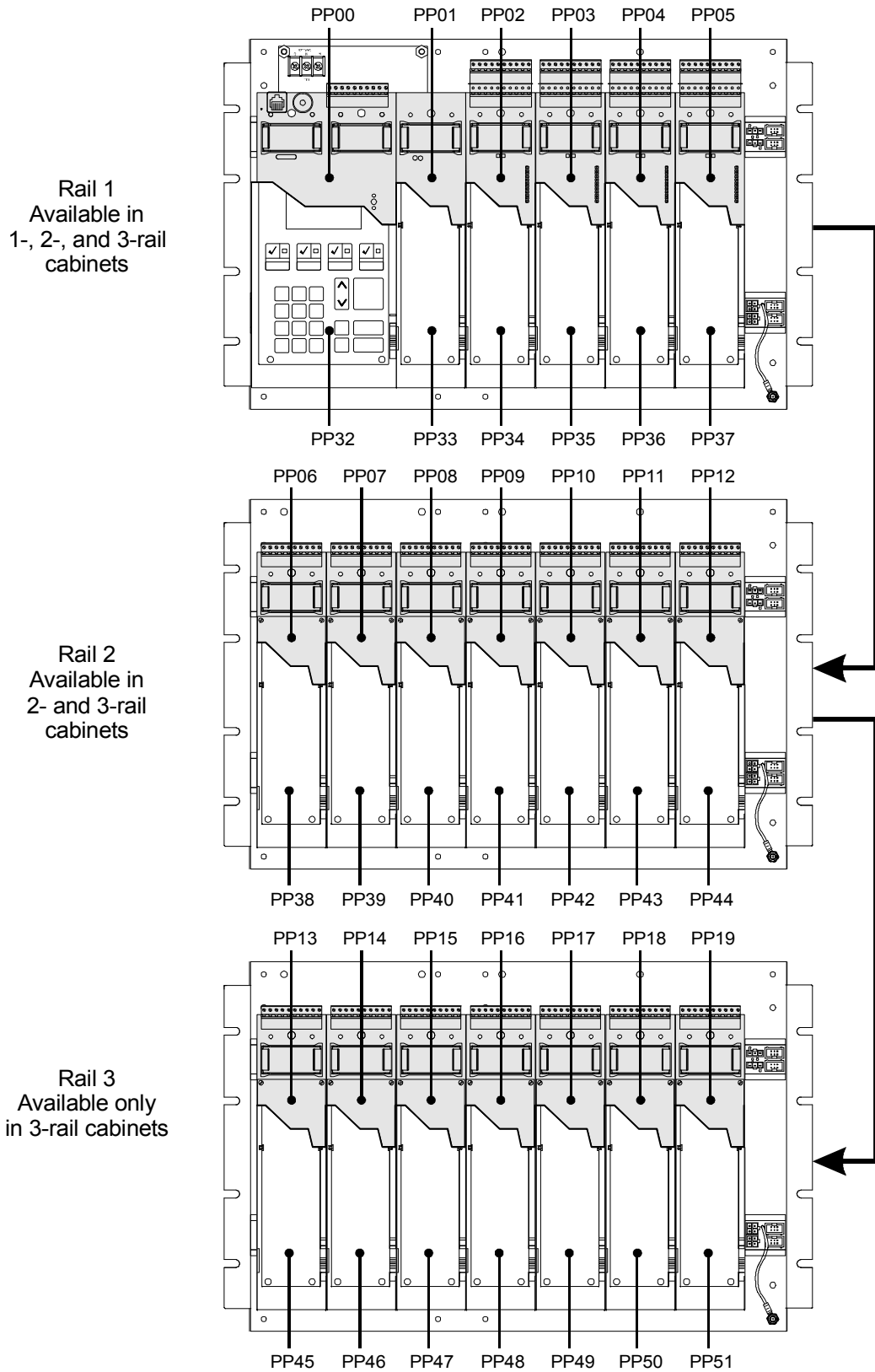

Figure A-4: LRM addresses for 3-CHAS7, 3-CHAS7, 3-CHAS7 configuration

Control / display module addresses

Figure A-5 shows the device logical addresses that the system assigns the control/display modules.

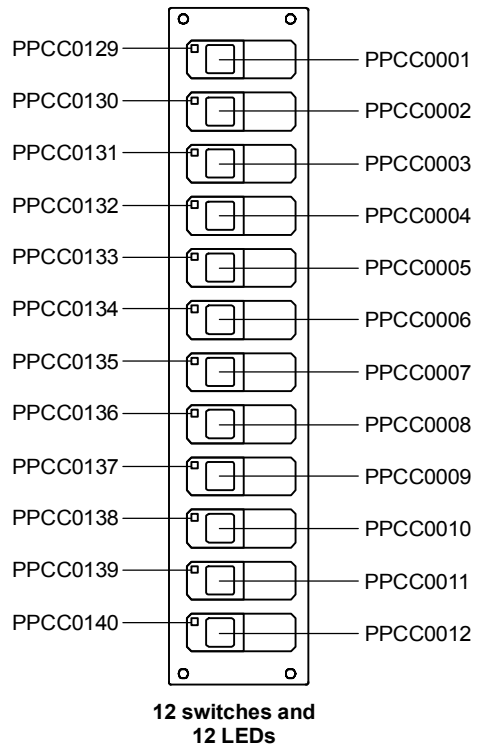
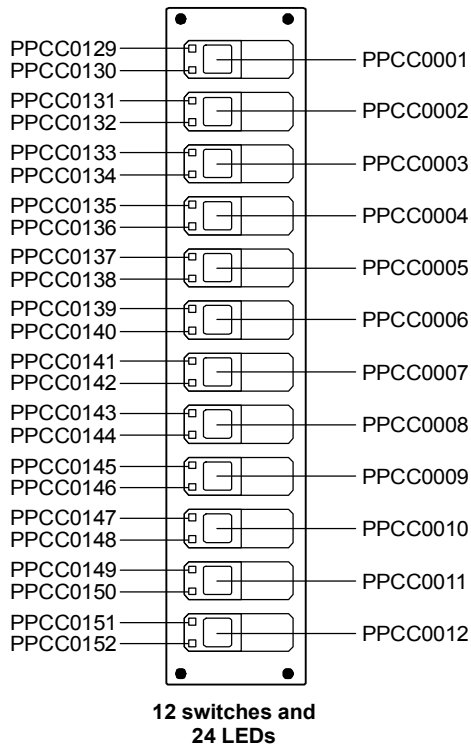
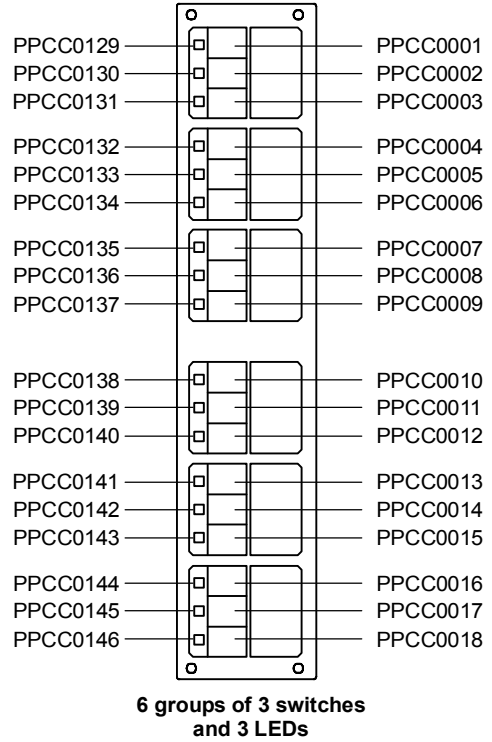
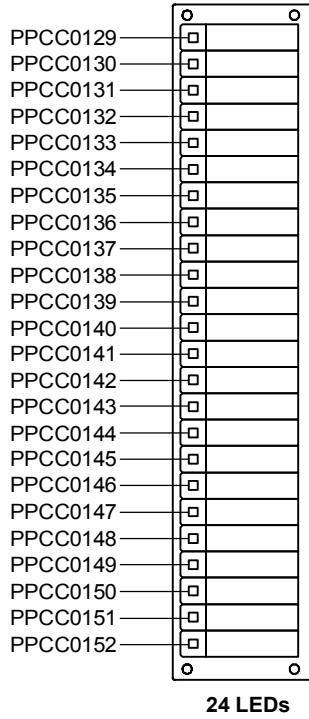

Figure A-5: Control/display module switch and LED device addresses

Device addresses

Figure A-6 shows the device logical addresses that the system assigns to various rail modules.

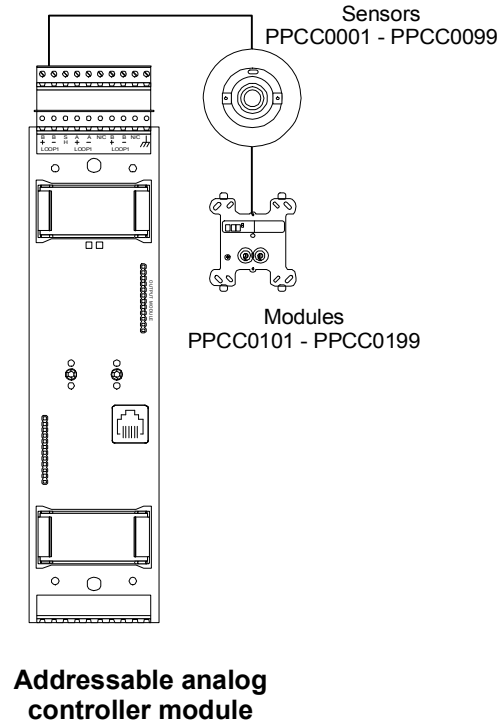
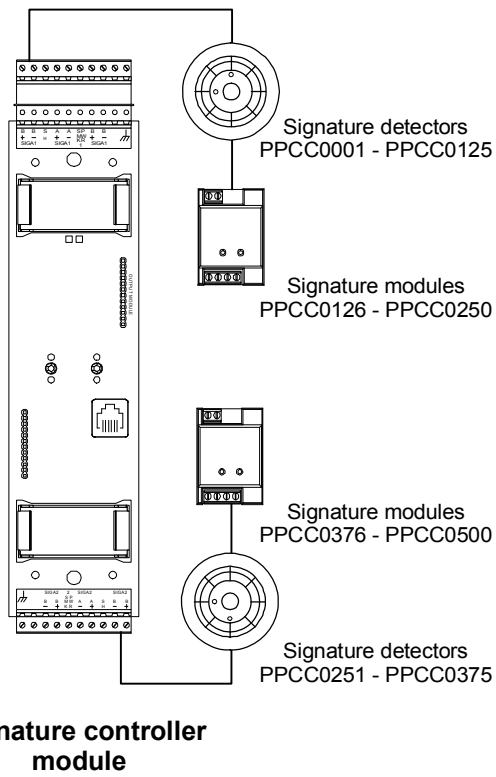
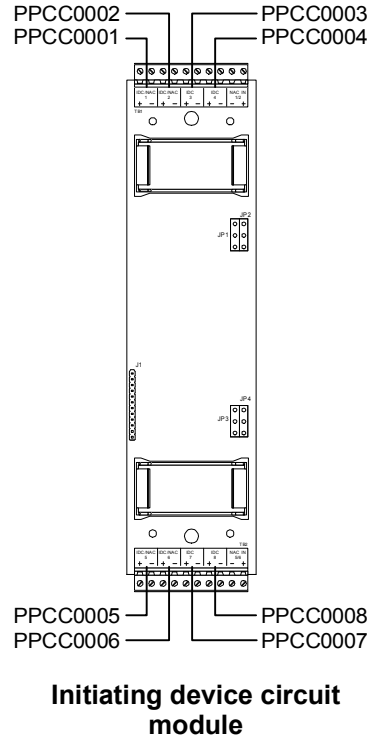
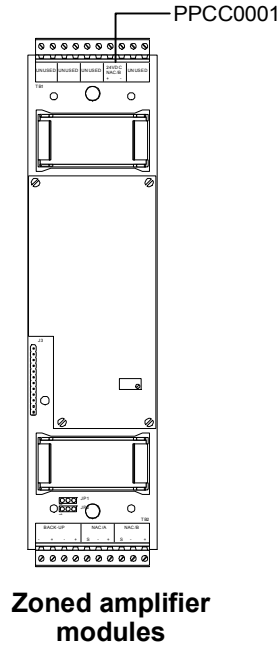

Figure A-6: Rail module device addresses

System addresses

Operation sequence charts

Summary

This appendix summarizes the operation of the system in a series of convenient charts.

Content

- Table B-1: Fire alarm sequence - LCD response • B.2
- Table B-2: Fire alarm sequence - common feature response • B.2
- Table B-3: Fire alarm sequence - zone annunciation • B.3
- Table B-4: Fire alarm sequence - notification appliance circuits (default operation) • B.3
- Table B-5: Fire alarm sequence - off premises connection • B.3
- Table B-6: Trouble sequence - LCD response [1] • B.4
- Table B-7: Trouble sequence - common feature response • B.4
- Table B-8: Trouble sequence - annunciation • B.4
- Table B-9: Trouble sequence - annunciation • B.5

Table B-1: Fire alarm sequence - LCD response

Event ► LCD display ▼	Normal	First alarm	Subsequent alarm	Alarm restore	Reset
Power LED	On	On	On	On	On
Alarm LED	Off	Flashing	Flashing	Flashing	Off
Trouble LED	Off	Off	Off	Off	Off
Panel buzzer	Off	On	On	Off	Off
LCD text display	Title screen	Current event and last window	Updates last event window	No change event latched until reset	Title screen
Alarm counter on LCD	0000	0001	0002	0002	0000
Alarm history counter on LCD	0000	0000	0000	0000	0001
Reset switch	Enabled	Disabled for silence Inhibit period	Enabled after Inhibit period expires	No change	Disabled

Table B-2: Fire alarm sequence - common feature response

Event ► LCD display ▼	Normal	First alarm	Subsequent alarm	Alarm restore	Reset
Alarm silence inhibit timer	Off	Timer starts	Runs until expired	No change	Off
Alarm silence LED	Off	Yellow after silence	Yellow after silenced	No change	Off
Alarm silence timer	Off	Timer starts, alarm silenced if timer expires	Restarts, alarm silenced if timer expires	No change	Off
Page inhibit timer	Off	Timer starts, prohibits paging until timer expires	No change	No change	Off
Auto general alarm signal timer (recycle)	Off	Timer starts, total EVAC if timer expires	No change unless canceled by user	No change	Off

Table B-3: Fire alarm sequence - zone annunciation

Event ► LCD display ▼	Normal	First alarm	Subsequent alarm	Alarm restore	Reset
Panel annunciator	Off	On red	On red	No change	Off
Printers	Ready	Prints event	Prints event	Prints on restoration	Off
History logger	Ready	Logs event	Logs event	Logs restoration	Ready

Table B-4: Fire alarm sequence - notification appliance circuits (default operation)

Event ► LCD display ▼	Normal	First alarm	Subsequent alarm	Alarm restore	Reset
General alarm audible notification circuits	Off	Sounds alarm	No change, resounds alarm if silenced	No change	Off
General alarm visual notification circuits	Off	Displays alarm indication	Displays alarm indication	Displays alarm indication	Off

Table B-5: Fire alarm sequence - off premises connection

Event ► LCD display ▼	Normal	First alarm	Subsequent alarm	Alarm restore	Reset
Reverse polarity alarm output	Off	Reverses polarity	No change	No change	Reverses polarity back to normal
Common alarm relay	Off	On	No change	No change	Off
Auxiliary control relays	Off	On as programmed	On as programmed	No change	Off

Table B-6: Trouble sequence - LCD response [1]

Event ► LCD display ▼	Normal	First trouble - trouble queue	First alarm w/active trouble - alarm queue	Notes
Current event window	Off	Trouble message	Alarm message	Alarm has priority
Last event window	Off	Trouble message	Alarm message	Alarm has priority
Queue LED	Off	Flashes yellow	Flashes red	

[1] 3-LCD and 3-LCDXL1 modules

Table B-7: Trouble sequence - common feature response

Event ► LCD display ▼	Normal	First trouble	First alarm w/active trouble	Notes
Panel buzzer	Off	Sounds trouble	Sounds alarm	Alarm has priority
Panel Silenced LED	Off	Off	Off	Yellow when local buzzer silenced
3-CPU3 Trouble Relay	On	Off	Off	Relay powered in normal state
3-CPU3 Alarm Relay	Off	Off	On	Remains on until panel reset

Table B-8: Trouble sequence - annunciation

Event ► LCD Display ▼	Normal	First trouble	First Alarm w/Active trouble	Notes
Panel zone LED	Off	On yellow	On red	
Remote annunciator alarm zone LED	Off	On yellow	Steady red	Alarm has priority if same LED is also used to annunciate trouble
Printers	Ready	Prints trouble message	Prints alarm message	Time, date, event message, & device data
History logger	Ready	Logs event	Logs event	Time, date, event message, & device data

Table B-9: Trouble sequence - annunciation

Event ► LCD display ▼	Normal	First trouble	First Alarm w/active trouble	Notes
Off premises module (3-OPS) 3 circuit configuration	All circuits normal polarity	Trouble circuit reverses polarity, module trouble relay operates	Alarm and trouble circuits reverse polarity	
Off premises module 1 circuit configuration	Normal polarity	Circuit opens, (module trouble relay operates)	Circuit reverses polarity (trouble relay restores)	Alarm has priority
Auxiliary control relays	Off	On as programmed	On as programmed	

Operation sequence charts

3

- 3-ASU
 - controls and indicators • 3.2
 - operating • 3.4
- 3-FTCU
 - controls and indicators • 4.2
 - operation • 4.4
- 3-LCD controls and indicators • 2.2

A

- Active points
 - identifying • 2.9
- Alarm silence/reset inhibit timer • 1.14
- Alternate message routing
 - activating • 2.22
- Alternate sensitivity
 - changing to primary • 2.21
- And groups
 - disabling • 2.10
 - enabling • 2.11
- Arming security partitions • 2.14
- Audio Source Unit
 - paging sequence • 3.5
 - paging with remote microphone • 3.6
 - phone page • 3.5
- Automatic alarm silence timer • 1.15
- Automatic general alarm (GA) timer • 1.15

B

- Button
 - operation • 1.15
- Buttons
 - disabling • 2.12
 - enabling • 2.13
- Bypassing security devices • 2.18

C

- Canceling the test • 2.32, 2.34
- Changing holidays • 2.30
- Changing the output state of a relay or LED • 2.23
- Changing the smoke detector sensitivity level • 2.21
- Changing user access level passwords • 2.28
- Clearing the panel history file • 2.31

D

- Date
 - entering • 2.27
- Default passwords • 2.28
- Deleting holidays • 2.30
- Device Maintenance report
 - creating • 2.24
 - description • 2.24

Devices

- disabling • 2.12
- enabling • 2.13
- Dirty head report
 - creating • 2.24
- Disabled points
 - identifying • 2.9
- Disabling hardware components • 2.12
- Disabling logical devices • 2.10
- Disarming security partitions • 2.16

E

- Enabling hardware components • 2.13
- Enabling logical devices • 2.11

G

- Guard patrol • 1.13
- Guard Patrol groups
 - disabling • 2.10
 - enabling • 2.11
- Guard patrols
 - activating • 2.20
 - restoring • 2.20

H

- Hardware components
 - disabling • 2.12
 - enabling • 2.13
- High priority
 - description • 2.23
- History report
 - creating • 2.24
- Holidays • 1.15
 - scheduling • 2.30

I

- Identifying active or disabled points • 2.9

L

- Lamp test • 2.35
- Latch priority
 - description • 2.23
- LEDs
 - changing the state of • 2.23
 - disabling • 2.12
 - enabling • 2.13
- Logical devices
 - disabling • 2.10
 - enabling • 2.11
- Low priority
 - description • 2.23

Index

M

- Matrix groups
 - disabling • 2.10
 - enabling • 2.11
- Medium priority
 - description • 2.23
- Modcom Compliance report
 - creating • 2.24
 - description • 2.24

P

- Panel sounder test • 2.35
- Password protection • 1.2
- Passwords
 - changing • 2.28
 - default • 2.28
- Primary message routing
 - restoring • 2.22
- Primary sensitivity
 - changing to alternate • 2.21
- Putting a service group into test • 2.32
- Putting a Signature device into test • 2.34

R

- Rail modules
 - disabling • 2.12
 - enabling • 2.13
- Relays
 - changing the state of • 2.23
- Removing bypasses from security devices • 2.19
- Reports • 2.24
- Restarting a panel • 2.29
- Restoring security partitions • 2.17
- Revisions report
 - creating • 2.24
 - description • 2.24

S

- Scheduling holidays • 2.30

- Security devices
 - bypassing • 2.18
 - removing bypass • 2.19
- Security partitions
 - arming • 2.14
 - disarming • 2.16
 - restoring • 2.17
- Service groups
 - disabling • 2.10
 - enabling • 2.11
- Set priority
 - description • 2.23
- Setting the system time and date • 2.27
- Signature devices, testing • 2.34
- Smoke detector sensitivity
 - description • 2.21
- Smoke detector sensitivity level
 - changing • 2.21
- System timers • 1.14

T

- Testing alarm input devices • 2.32
- Testing Signature devices • 2.34
- Testing, lamp • 2.35
- Testing, LEDs • 2.35
- Testing, panel sounder • 2.35
- Time controls • 1.15
 - holidays • 1.15
- Time Controls
 - disabling • 2.10
 - enabling • 2.11
- Time of day
 - entering • 2.27

Z

- Zone groups
 - disabling • 2.10
 - enabling • 2.11